

TECHNICAL GUIDE

Integrated safety devices



Content index

Technical data	4
Dreawings.....	5
Electrical scheme	6
Order sheet.....	7

Technical data

Description and functions	Measure	Checking test value
Oil level (Float) The device indicates any gas evolution or oil level variation. - Slight oil level variation or any insignificant gas evolution is denoted by the float position between "MIN" & "MAX" on the display. - At major oil variation level or gas evolution the float stops at "MIN" and opens/closes the alarm circuit. - Any accumulated gas can be drawn off by the valve provided.	Max 150 cm ³	Locate the magnet close to the float (between MAX and MIN). Drawn it downwards until it reaches "MIN". To reset the float to its correct position draw the magnet upwards and detach.
Pressure (Pressure switch) This feature measures the internal pressure of transformer. The normal level is to be set by the user according to the transformer manufacturer's instructions. When pressure exceeds a pre set level the alarm circuit is triggered by a change over contact.	100 mbar to 500 mbar	With the internal pressure at least 100mbar set the adjusting knob of the pressure switch to minimum.
Temperature "T2" Thermostat switch (Alarm) The feature measures the internal oil temperature of the transformer. The normal operating value is to be set by the user according to the transformer manufacturers instructions. At a pre set temperature the alarm circuit is triggered by a change over contact (T2).	30°C to 120°C	Open the rear cover using both hands, do not lever at one side only. The adjustment knob of the alarm switch "T2" should be set to the minimum value.
"T1" Thermostat switch (Stop) The feature measures the internal oil temperature of the transformer. The normal operating value is to be set by the user according to the transformer manufacturers instructions. At a pre set temperature the stop circuit is triggered by a change over contact (T1).	30°C to 120°C	The adjustment knob of the stop switch "T1" should be set to zero. The adjustment knob of the stop switch "T1" should be set to the minimum value.
Thermometer The device measures the internal temperature of the transformer, which shall be visualized outside the device through the protection window. The thermometer is equipped with a drag pointer.	30°C to 160°C	The protection window is to be unscrewed so that the pointer shall be set to the minimum values.

General feature

Degree of protection (EN 60529)	IP66
Suitable for Offshore application	1000 h
UV-Ray resistance (UNI-ISO 4892 / UNI-ISO 4582)	500 h
Measuring range	40°C to +120°C
Environment temperature	-40°C to 55°C
Cable connection	M 25 x 1.5
Cable box (EN 50005 / EN 60947-7-1 / IEC 947-7-1)	According to standard
Wire section to be used on clamp box	Up to 2.5 mm ²
Max. rated pressure	500 mbar, different pressure are available on demand. Contact us for other options (comemservice@it.comem.com)
Electrical characteristics	Double insulation

Current	ac						dc					
	Ohmic			Ohmic inductive (cosφ > 0,5)			Ohmic			Ohmic inductive (L/R < 40ms)		
Voltage	220	127	24	220	127	24	220	127	24	220	127	24
Electric rating	Oil level	2A	2A	2A	2A	2A	2A	2A	2A	2A	2A	2A
	Pressure switch	6A	6A	6A	2A	2A	2A	0,6A	0,6A	0,6A	0,6A	0,6A
	Thermostat	16A	16A	16A	4A	4A	4A	0,6A	0,6A	0,6A	0,2A	0,3A

Analogue Output for eRIS2

Temperature	4-20 mA proportional to the measuring temperature range (40°C - 4 mA ... 120°C - 20mA)
Pressure	4-20 mA proportional to the pressure range (0 mbar - 4 mA ... 500 mbar - 20mA)*
Max distance for analogue output	Max 30 m / 98 ft. Contact us for other options (customerservice@it.comem.com)

*1000 mbar - 20mA is available on demand

Drawings

RIS2/eRIS2 standard

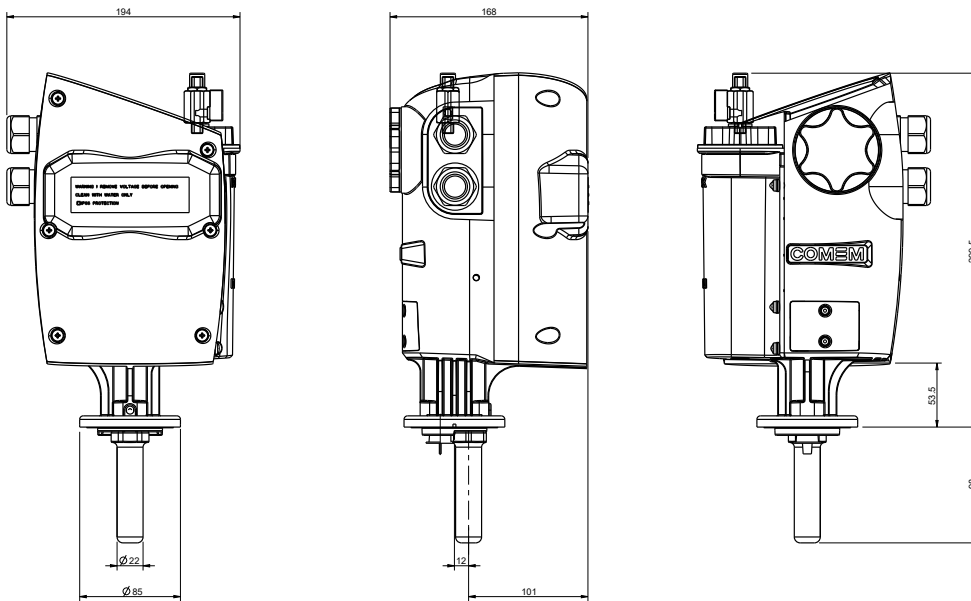

RIS2/eRIS2 for transformer with conservator

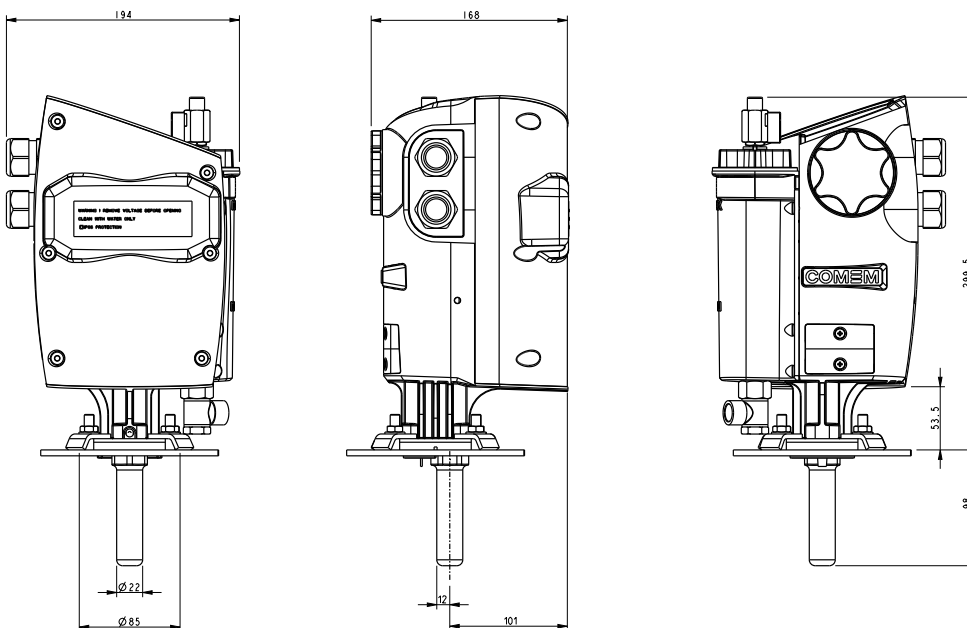

Electrical connection eRIS2

Wiring diagram

- Temp. TRIP "T1" (terminals 44-41-42)
- Temp. ALARM "T2" (terminals 34-31-32)
- Pressure (terminals 24-21-22)
- Oil level (terminals 14-11-12)
- Temperature: Analogue output 4-20mA
- Pressure: Analogue output 4-20mA (Option)

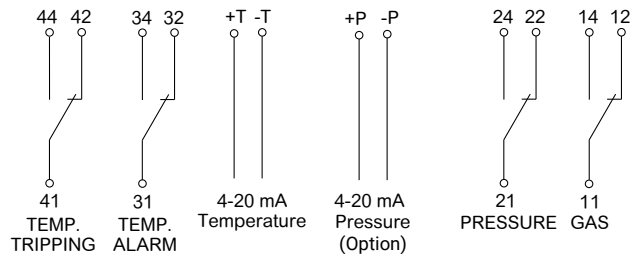

Electrical connection RIS2

Wiring diagram

- Temp. TRIP "T1" (terminals 44-41-42)
- Temp. ALARM "T2" (terminals 34-31-32)
- Pressure (terminals 24-21-22)
- Oil level (terminals 14-11-12)
- Options (flagged if present):
 - 2nd pressure switch
 - PT100

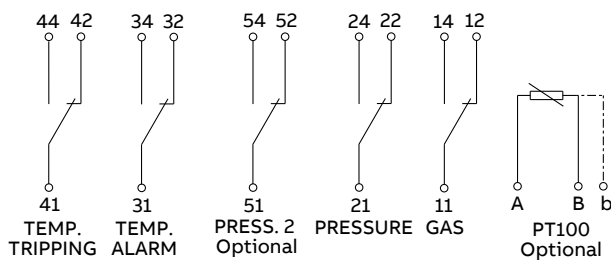

Special wiring diagram

"6 switches" – upon request

- Temp. TRIP "T1" (terminals 44-41-42)
- Temp. ALARM "T2" (terminals 34-31-32)
- Pressure 1 (terminals 24-21-22)
- Pressure 2 (terminals 54-51-52)
- Oil level 1 (terminals 14-11-12)
- Oil level 2 (terminals 64-61-62)

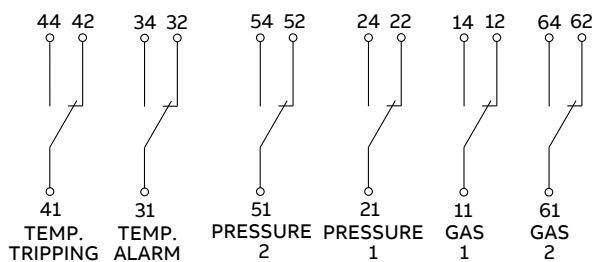

Order sheet

Date	
Rev.	
Customer reference	

Type

<input type="checkbox"/>	RIS2
<input type="checkbox"/>	RIS2 (offshore)
<input type="checkbox"/>	eRIS2 (only offshore)

Gasket Material

<input type="checkbox"/>	NBR (from -40 up to 120°C) (Standard)
<input type="checkbox"/>	HNBR (From - 40°C upto +140°C)
<input type="checkbox"/>	Viton (from -10°C upto +150°C)
<input type="checkbox"/>	Fluorosilicone (from -60°C upto +200°C)

Electrical Scheme

<input type="checkbox"/>	Standard
<input type="checkbox"/>	Special (valid only for RIS2 – see page 6)

Thermostat Setup

<input type="checkbox"/>	T1=100°C T=90°C (Standard)
<input type="checkbox"/>	T1=95°C T=85°C
<input type="checkbox"/>	T1=105°C T=95°C
<input type="checkbox"/>	T1=100°C T=80°C
<input type="checkbox"/>	Customize T1
<input type="checkbox"/>	Customize T2

Pressure Setup

<input type="checkbox"/>	0,1-0,5 bar (Standard)
<input type="checkbox"/>	0,7 bar
<input type="checkbox"/>	Customize P1
<input type="checkbox"/>	Customize P2 (in case of double pressure switches)

N° of cable gland

<input type="checkbox"/>	1 (Standard)
<input type="checkbox"/>	2

Added output (optional for RIS2)

<input type="checkbox"/>	NO (Standard)
<input type="checkbox"/>	N°1 PT100

eRIS2 Analogue Output

<input type="checkbox"/>	N°1 Temperature Analogue Output (Standard)
<input type="checkbox"/>	N°1 Temperature and N°1 Pressure Analogue Output

eRIS2 Pressure Range

<input type="checkbox"/>	0/500 mbar (Standard)
<input type="checkbox"/>	±1000 mbar

Transformer type

<input type="checkbox"/>	Hermetically sealed (Standard)
<input type="checkbox"/>	With conservator

For further information or clarification, please contact our support team. E-mail address: customerservice@it.comem.com

COMEM is an ISO 9001 system certified. Information subject to change without notice

COMEM SpA

Localita' Signolo 22, S.R.11
36054 Montebello Vicentino
Vicenza - Italy
Tel +39 0444 449 311

www.comem.com

The data and illustrations are not binding. We reserve the right to modify the contents of this document without prior notice following the technical and product developments.

Copyright 2024 COMEM. All rights reserved

Technical guide-01-2024