

TECHNICAL GUIDE

Contactless Liquid Level indicators



Content index

Contactless Liquid Level Indicators	
CU eOLI	
Technical data	4
Dimensions and electrical scheme.....	5
Remote Visual Indicator eViewer	
Technical data	7
Dimensions and electrical scheme.....	8
Order sheet	9

Contactless Liquid Level Indicators CU eOLI

Technical data

CU eOLI	Technical data
Material	
Housing and upper part inclusive terminal box	C4-MEDIUM: Aluminum casting, RAL 7032, powder coated (standard); C5-MEDIUM: coastal area; surface treatment, not painted (on request) CX Offshore
Characteristics data	
Installation	Indoors and outdoors, tropical proof
Measurement ranges for CU eOLI100	120 mm - 1000 mm
Measurement ranges for CU eOLI200	200 mm - 2000 mm
Ambient temperature	-25°C to +70°C
Oil temperature	-25°C to +70°C
Gasket material	NBR
Degree of protection	IP65 in accordance with EN60529
Protected micro switches	
Number and types	1 programmable changeover
Making capacity	5A @30V DC – 10A @250V AC
Max breaking capacity DC	3A
Max breaking capacity AC	5A
Connection	
Connection terminals	Min 0.25 mm ² / max. 4 mm ²
Cable glands	N°2 M25 x 1.5
Mechanical test	
Sinusoidal (EN 60721-3-4)	cl.4M4
Shock	cl.4M4
Electronic board features	
Analog output	4-20 mA (dielectric strength between electronic card and analogical output: 2kV) Maximum resistance: 450 Ω
Digital output	Serial RS485 for MODBUS RTU
Rated voltage	24 VDC ±10% polarized
EMC guaranteed	Cable length up to Max 30 m / 98 ft
Accuracy and Repeatability	1.0% of full scale*
Current consumption	<0.2A
Ventilation valve	To prevent the formation of condensation

*Working pressure (absolute) value shall be above 600mbar

COMEM is an ISO 9001 system certified. Information subject to change without notice

Sensor characteristics

Sensor type	Ultrasonic
Reading area	Ø 250 mm for CU eOLI100; Ø 500 mm for CU eOLI200 (See below)
Sensor offset	120 mm for CU eOLI100 ; 200 mm for CU eOLI200 (See below)

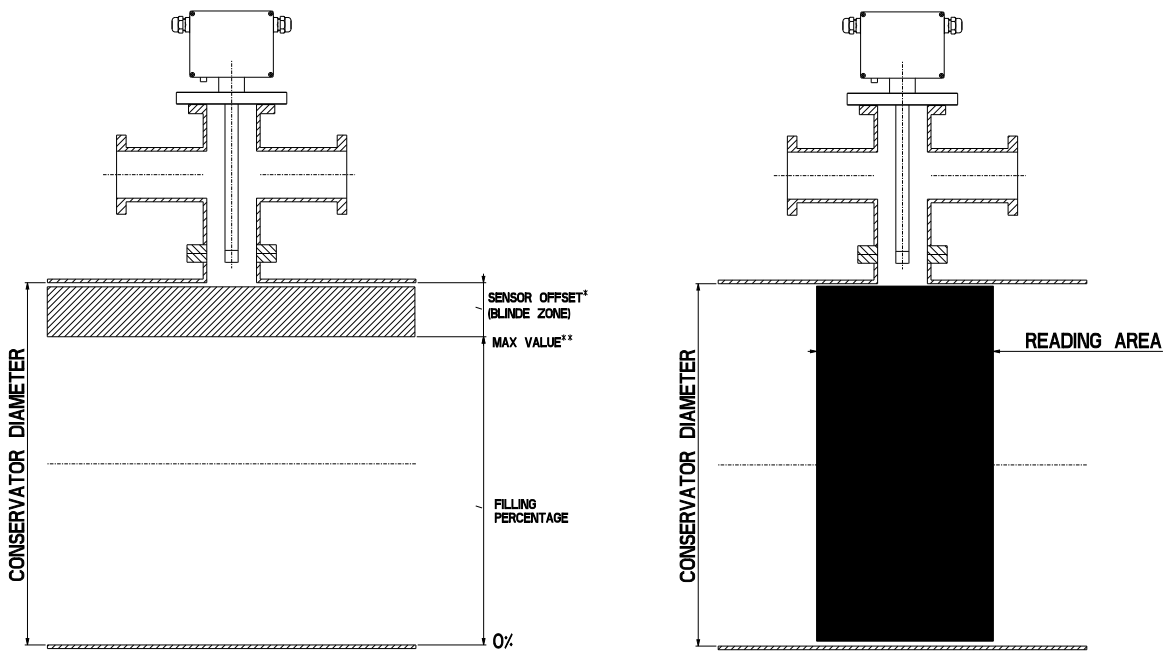

* equal to: 120mm for Cu eOLI100/ 200mm for Cu eOLI200
 ** in absence of installation offset (without rubber bag) MAX VALUE (%)
 is equal to: (conservator diameter - blind zone)*100/ conservator diameter

Contactless Liquid Level Indicators CU eOLI

Dimensions and electrical scheme

CU eOLI dimensions

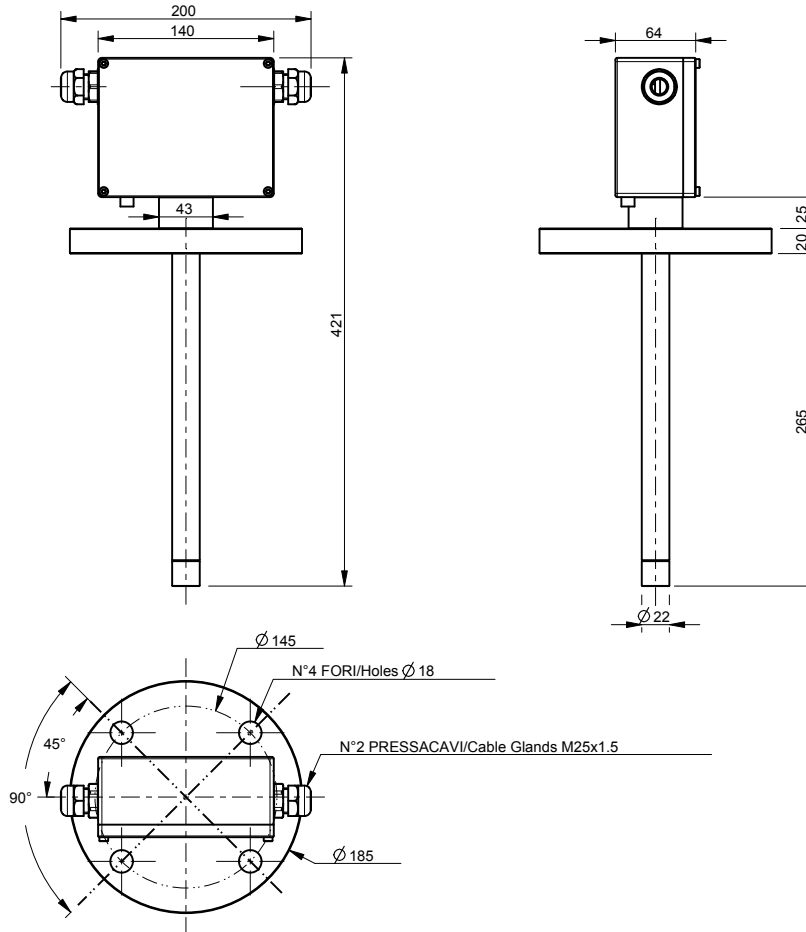

CU eOLI electrical scheme

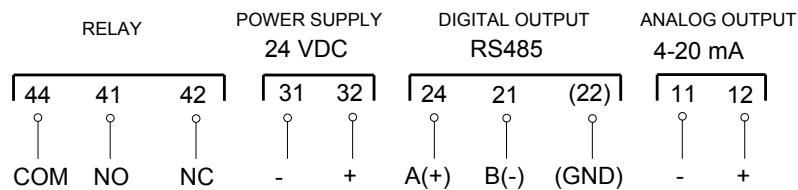

Remote Visual Indicator eViewer

Technical data

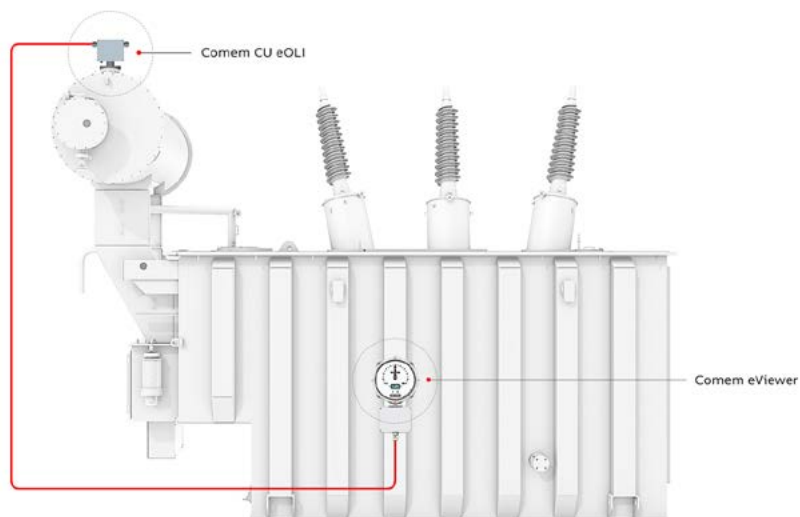

Connection

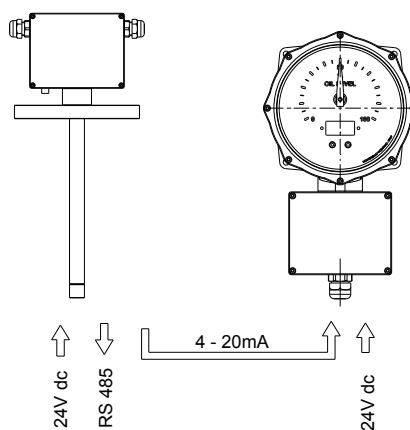

Electronic board features

Analog input	4-20 mA
Rated voltage	24 VDC \pm 10% polarized
Current consumption	<0.05A
Wires	Max 2.5mm ² – advised 4x1mm ² or 6x1mm ² shielded twisted pair cable for analog/digital output
EMC guaranteed	Cable length up to 30 m / 98 ft
Ventilation valve	To prevent the formation of condensation

Remote Visual Indicator eViewer

Dimensions and electrical scheme

eViewer dimensions

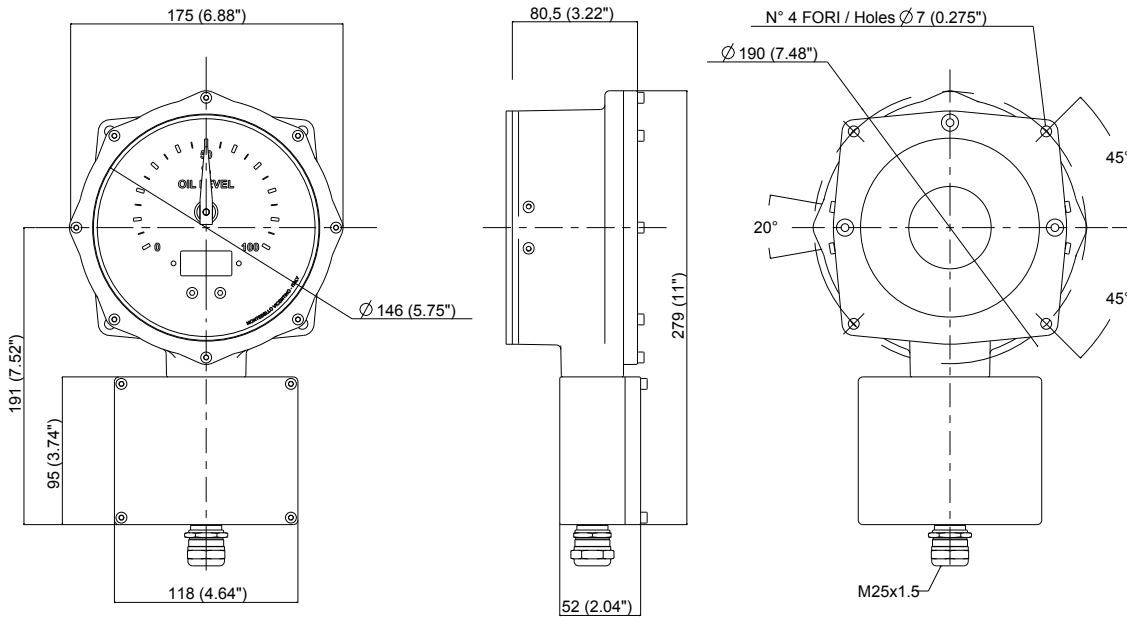

eViewer electrical scheme

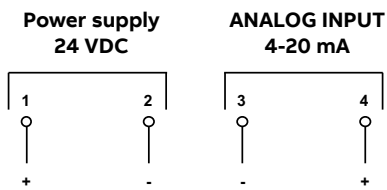

Order sheet

Date	
Rev.	
Customer reference	

Type

<input type="checkbox"/>	CU eOLI100 (conservator diameter up to 1,000mm)
<input type="checkbox"/>	CU eOLI200 (conservator diameter up to 2,000mm)

Remote visual indicator

<input type="checkbox"/>	eViewer
--------------------------	---------

Conservator diameter

Indicate value in mm:	
-----------------------	--

Application

<input type="checkbox"/>	Conservator without rubber bag (Fig.1, pag 8)
<input type="checkbox"/>	Conservator with rubber bag (Fig.2, pag 9)

Relay configuration

<input type="checkbox"/>	Thresholds (Min 25% - MAX 75%, default)
<input type="checkbox"/>	Fail safe (Power supply loss detection)
<input type="checkbox"/>	Fail Safe + Thresholds

Corrosion class

<input type="checkbox"/>	C4 Medium acc. to ISO 12944 (standard)
<input type="checkbox"/>	C5 Medium acc. to ISO 12944 (not paintable)
<input type="checkbox"/>	CX acc. to ISO 12944 (on request)

Type for coservator without rubber bag

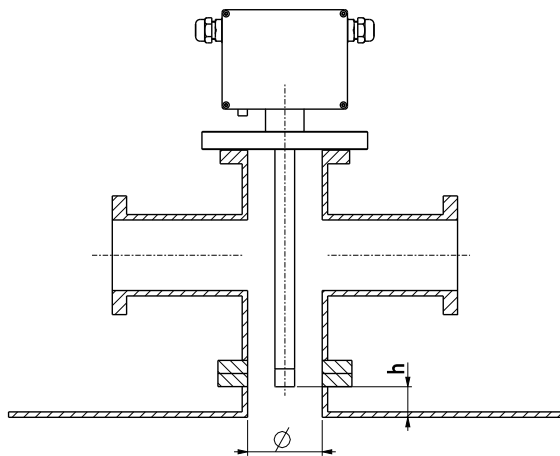
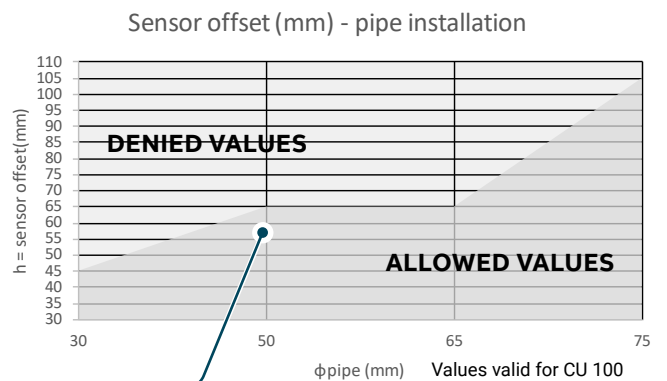

Fig 1

Indicate value in mm

h	
Ø	

Sensor offset (mm) - pipe installation



Recommended setup
 $\phi = 50\text{mm}$
 $h = 60\text{mm}$

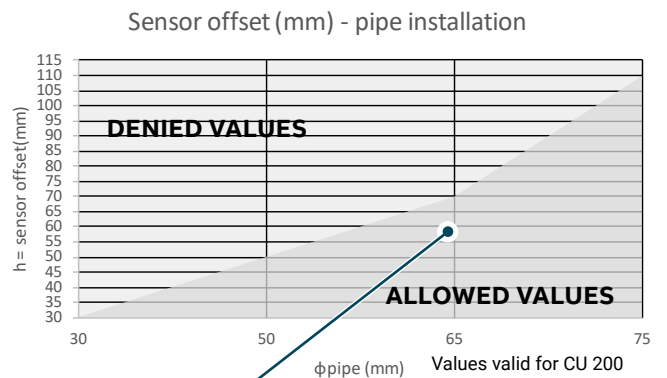

Recommended setup
 $\phi = 65\text{mm}$
 $h = 60\text{mm}$

Order sheet

Type for conservator with rubber bag

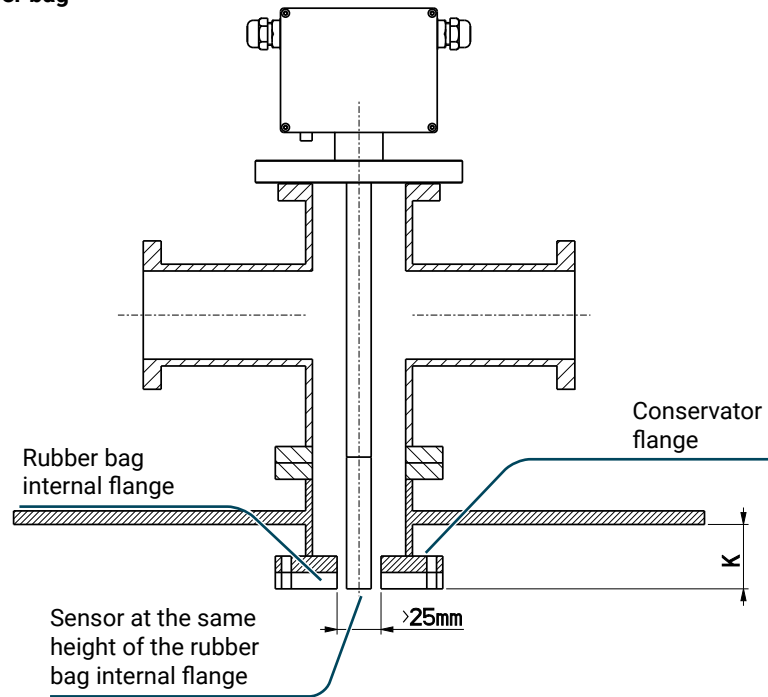

Fig 2

Indicate value in mm

k	
---	--

COMEM SpA

Localita' Signolo 22, Sr11
36054 Montebello Vicentino
Vicenza - Italy
Tel +39 0444 449 311

www.comem.com

The data and illustrations are not binding. We reserve the right to modify the contents of this document without prior notice following the technical and product developments.

Copyright 2022 COMEM. All rights reserved

Technical guide-08-2022