

TECHNICAL GUIDE

Conventional breathers



Content index

Application	4
Technical data	5
Dimensions.....	6
Order sheet.....	9

Application

Type	Features (available for standard version)									Options	
	Quantity of Oil (t) (a)	Silica gel Volume (dm ³)	Silica gel Weight (Kg)	Corrosion protection: C4. Moderate salinity ISO 12944	Hydraulic closing	Mechanical closing	Polycarbonate tube and oil pocket	Flange connection	Female connection	Glass tube and oil pocket ISO 1294	Corrosion protection: C5 Off Shore
E11	0÷2	0.25	0.2	●	●	-	●	-	●	-	-
1	2÷4	0.46	0.37	●	●	●	●	-	●	●	●
2	4÷8	0.95	0.76	●	●	●	●	●	●	●	●
3	8÷14	2.75	2.2	●	●	●	●	●	●	●	●
4	14÷20	6.5	5.2	●	●	●	●	●	●	●	●
5	20÷40	13.3	10.5	●	●	●	●	●	●	●	●
6	40÷60	19	15.2	●	●	●	●	●	●	●	●
7	60÷80	32	25.6	●	●	-	●	●	-	●	●
8	>80	58	46.3	●	●	-	●	●	-	●	●

(a) The oil quantities assigned to size classes are oriented on normal European ambient condition as given in IEC 60076-22-7. The values are intended to give guidance to the user: The proper choice must take into consideration the real environmental conditions, the thermal cycles due to the service conditions of the transformer and the maintenance cycle.

Technical data

Technical data	
Material	All the external part are resistant to transformer oils, salt fog and UV rays
Color	RAL 7032
Protection tube material	Standard: Polycarbonate Optional: Glass (for critical environments, ex. desert) not available for Comem E11
Standard	IEC 60076-22-7
Ambient temperature	-40°C to 80°C / -40°F to 176°F
Gaskets	NBR (Standard)
Additional bracket for the lower part	Only for types Comem 7 and Comem 8
Desiccant	Colored, non-poisonous; amount according application table above (The color change from orange to green absorbing humidity)
Protection	Stainless steel pipe protection against accidental blows, with opening that allow visual inspection on the salt
Pressure Load Loss of air through the dehumidifier	0.003 Kg /cm ² for inlet air, 0.005 Kg/cm ² for outlet air

Dimensions

Type hydraulic flanged (DA) - type hydraulic threaded (DB)

Type DA

Type DB

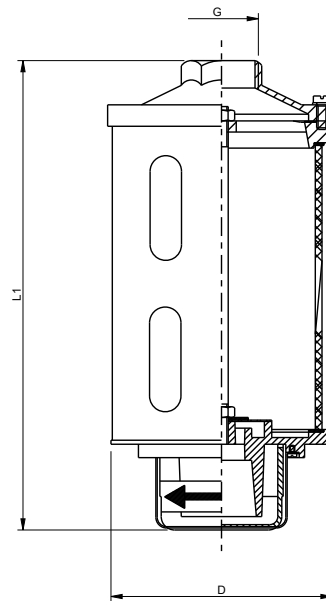
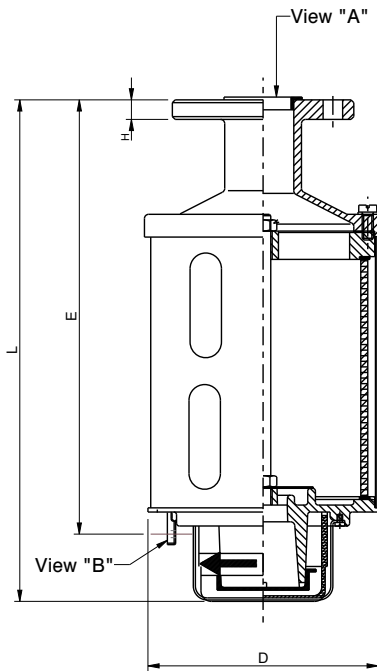

View "B"
(Bracket available for types 7-8)

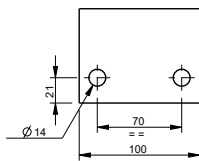

View "A"

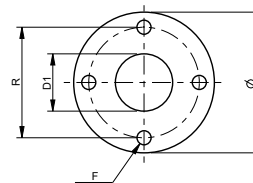

Type	L Tol.±5 mm	L1 Tol.±5 mm	D1 mm	H mm	Ø mm	R mm	F mm	G UNI-ISO228	E mm	D Tol.±5 mm	DA Kg	DB Kg
2	265	210	30	12	100	75	12	G1	-	140	3	2.7
3	360	310	44	14	130	100	14	G1 ½	-	175	5.4	5
4	610	560	44	14	130	100	14	G1 ½	-	175	9.4	8.8
5	675	625	57	15	140	110	14	G2	-	220	16.7	16.5
6	895	845	57	15	140	110	14	G2	-	220	22.5	22.2
7	840	-	57	15	140	110	14	-	728	330	40.6	-
8	1225	-	57	15	140	110	14	-	1113	330	65.3	-

Type mechanical flanged (MA) - type mechanical threaded (MB)

Type MA

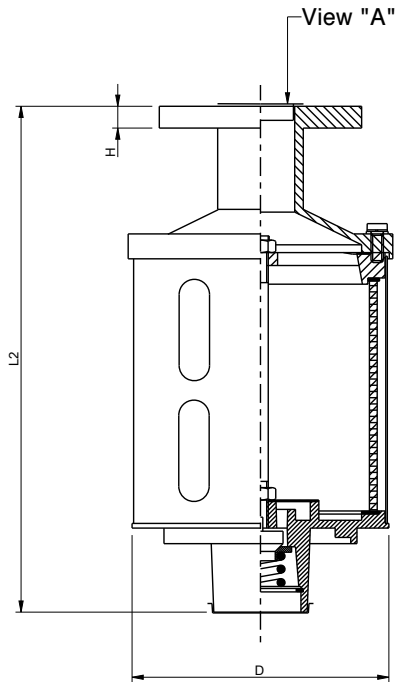

Type MB

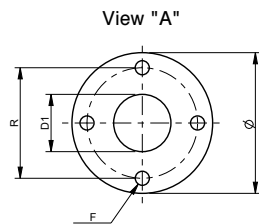
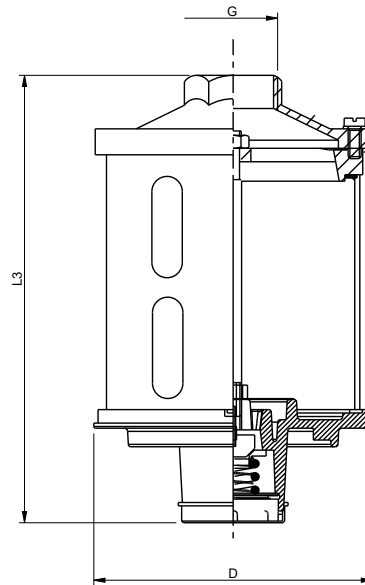

Type	L2 Tol.±5 mm	L3 Tol.±5 mm	D1 mm	H mm	Ø mm	R mm	F mm	G UNI-ISO228	D Tol.±5 mm	MA Kg	MB Kg
2	260	210	30	12	100	75	12	G1	140	2.7	2.5
3	350	300	44	14	130	100	14	G1 ½	175	5.2	5
4	600	550	44	14	130	100	14	G1 ½	175	8	7.8
5	660	615	57	15	140	110	14	G2	220	16.5	16.2
6	880	835	57	15	140	110	14	G2	220	22.5	22.2

Dimensions

Type 1DB - 1MB

Type 1DB

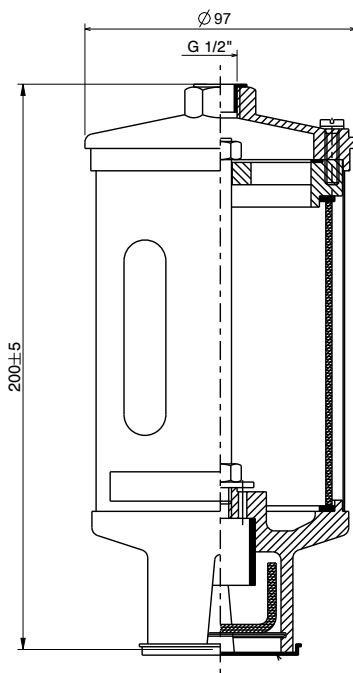

Type 1MB

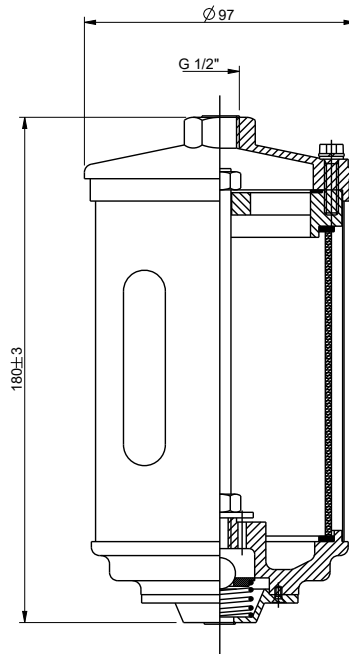

Type E11

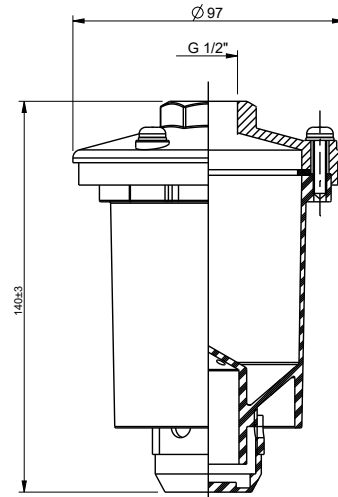

Type 1DB - 1MB

Type	Silica gel (dm ³)	Weight (Kg)
1DB	0.5	1.3
1MB	0.5	1.3

Type E11

Type	Silica gel (dm ³)	G – UNI-ISO 228	Weight (Kg)
E11	0.25	G3/8	0.4
E11	0.25	G1/2	0.4

Order sheet

Date	
Rev.	
Customer reference	

Type	Quantity of oil (t)
E11	0 to 2
1	2 to 4
2	4 to 8
3	8 to 14
4	14 to 20
5	20 to 40
6	40 to 60
7	60 to 80
8	>80

Corrosion withstand class

Standard	:C4 acc. to ISO 12944; RAL 7032
Optional	:C5-M acc. to ISO 12944 (Not paintable)

Protection material: tube and oil pocket*

Standard	: Polycarbonate
Optional	: Glass, not available for type E11

* For type 7 and 8 the oil pocket is available in glass only

Bottom closing type	Reference
Hydraulic	Fig. 1 Type D
Mechanical (not available for type Comem 7, Comem 8 and Comem E11)	Fig. 2 Type M

Connection	Reference
EN Flange (not available for type 1 and E11)	Fig. 3 Type A
Female thread (not available for type 7 and 8)	Fig. 4 Type B

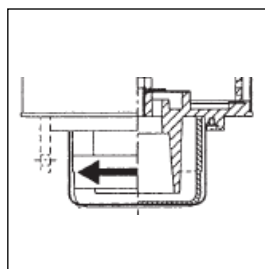

Fig. 1 Type D

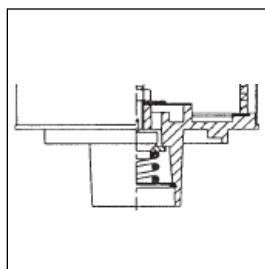

Fig. 2 Type M

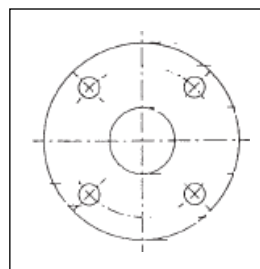

Fig. 3 Type A

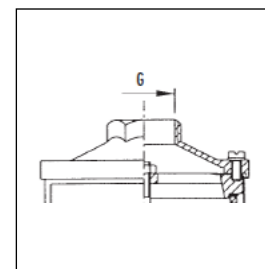

Fig. 4 Type B

COMEM SpA

Localita' Signolo 22, S.R.11
36054 Montebello Vicentino
Vicenza - Italy
Tel +39 0444 449 311

www.comem.com

The data and illustrations are not binding. We reserve the right to modify the contents of this document without prior notice following the technical and product developments.

Copyright 2024 COMEM. All rights reserved

Technical guide-05-2024