

PRODUCT CATALOGUE

Porcelain oil bushings

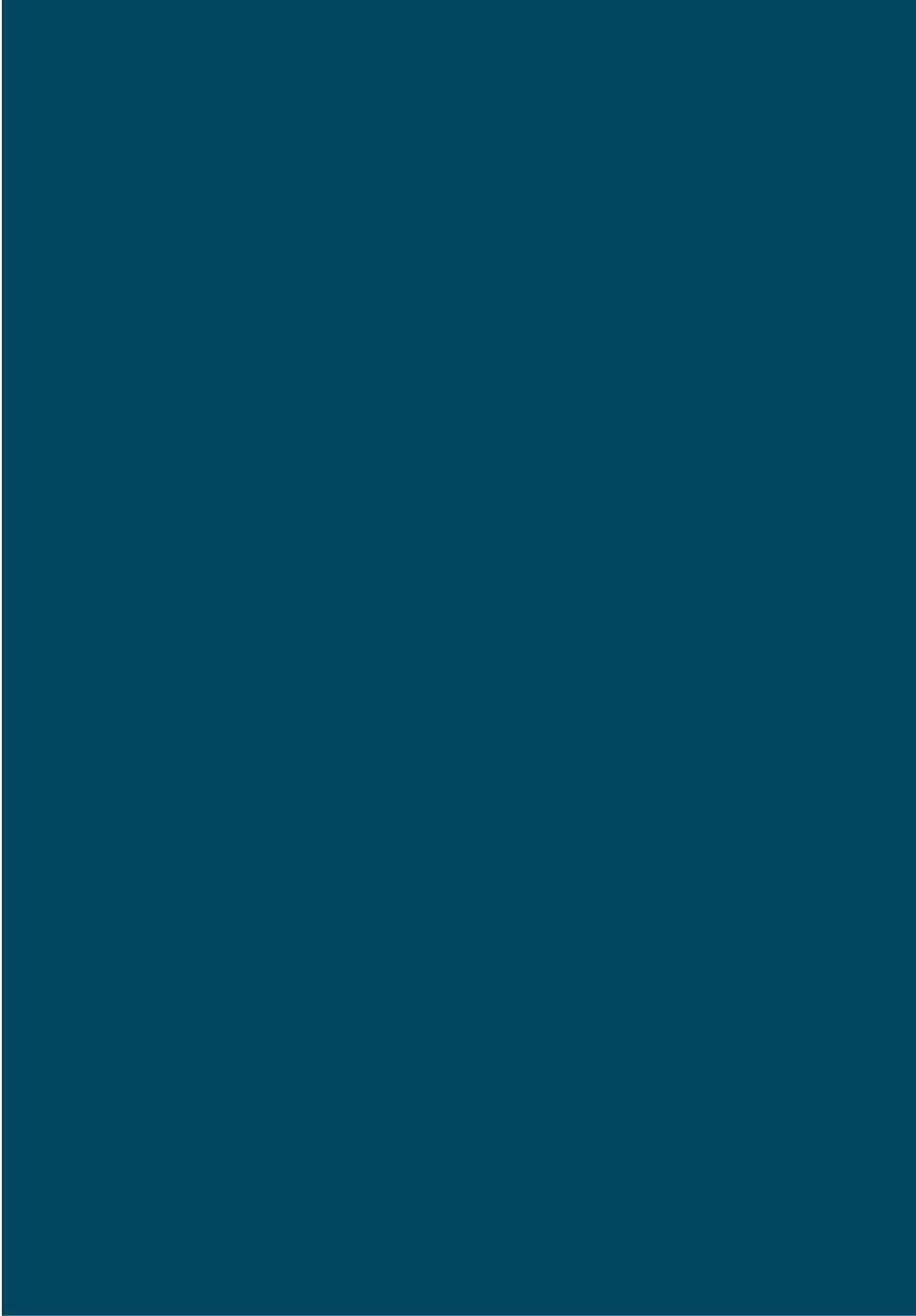



Product description

Porcelain insulation is impervious to moisture and grants successful operation over many years.

We offer wide range of non-condenser porcelain bushings for low voltage and medium voltage applications, including connecting flags for the insulators.

This catalogue gives as much information as possible concerning the electrical characteristics and dimensions of porcelain bushing for liquid-filled transformers. All drawings and related components are numbered for quick and correct identification of each part.

This catalogue is divided into three sections:

- Porcelain bushings for low voltage applications (A)
- Porcelain bushings for medium voltage applications (B)
- Connecting flags for bushings (C)

All metal parts are made using the most advanced machining and pressing technologies.

All insulators are subjected to electrical tests in compliance with current IEC standards.

Machining tolerances and the characteristics of raw materials comply with UNEL, DIN, CENELEC and UNE standards.

This catalogue does not include all the products we can supply.

General index

A - Porcelain bushings for low voltage applications - Insulation class 1÷3 kV Rated current 250÷6500 A

A	According	Nominal Voltage	Rated current	No. Page
A ₁	DIN 42530-68 - DIN 42539-68	1 ÷ 3 kV	250 A ÷ 630 A	5
A ₂	DIN 42530-68 - DIN 42539-68	1 ÷ 3 kV	1000 A ÷ 3150 A	7
A ₃	EN 50386	1 kV	250 A Solution "A"	9
A ₄	EN 50386	1 kV	250 A Solution "B"	10
A ₅	EN 50386	1 kV	630 A Solution "A"	12
A ₆	EN 50386	1 kV	630 A Solution "B"	13
A ₇	EN 50386	1 kV	1250 A Solution "A"	15
A ₈	EN 50386	1 kV	1000 A ÷ 1250 A Solution "B"	17
A ₉ Type A	EN 50386	1 kV	2000 A ÷ 5000 A	19
A ₉ Type B	EN 50386	1 kV	2000 A ÷ 5000 A	21
A ₁₀	Comem	3 kV	4500 A	23
A ₁₁	Comem	3 kV	6500 A	25

B - Porcelain bushings for medium voltage applications - Insulation class 12÷52 kV Rated current 250÷8000 A

B	According	Nominal Voltage	Rated current	No. Page
B ₁	DIN 42531	12 kV ÷ 36 kV	250 A	27
B ₂	DIN 42532	12 kV ÷ 36 kV	630 A	29
B ₃	DIN 42533	12 kV ÷ 36 kV	1000 A ÷ 3150 A	31
B ₄	DIN 42534	52 kV	1000 A ÷ 3150 A	33
B ₅	EN 50180	12 kV ÷ 36 kV	250 A	35
B ₆	EN 50180	12 kV ÷ 36 kV	630 A	37
B ₇	EN 50180	12 kV ÷ 36 kV	1250 A ÷ 3150 A	39
B ₈	EN 50180	52kV	1250 A ÷ 3150 A	41
B ₉	Comem	36 kV	250 A	43
B ₁₀	Comem	52 kV	250 A ÷ 630 A	45
B ₁₁	Comem	24 kV	6300 A	47
B ₁₂	Comem	12 kV ÷ 36 kV	4500 A	49
B ₁₃	Comem	52 kV	1000 A ÷ 3150 A	51
B ₁₄	DIN 42541	24 kV ÷ 36 kV	5000 A ÷ 8000 A	53
B ₁₅	EN 50243	24 kV ÷ 36 kV	5000 A ÷ 8000 A	55

C - Connecting flags for bushings

Type	According	Rated current	No. Page	Type	According	Rated current	No. Page
DP	DIN 43675-75	630 A	58	2-009	Comem	250 A	64
DR	DIN 43675-75	630 A	58	AF 06	Comem	630 A	64
EP	DIN 43675-75	1000 A	59	AF 1	Comem	1000 A	65
ER	DIN 43675-75	1000 A	59	10-086	Comem	1000 A	65
FP	DIN 43675-75	2000 A ÷ 3150 A	60	AF 2	Comem	2000 A	66
FR	DIN 43675-75	2000 A ÷ 3150 A	60	20072	Comem	2000 A	66
TP 78-120	DIN 43675-75	5000 A	61	AF 3	Comem	3150 A	67
TP 78-180	DIN 43675-75	8000 A	61	31073	Comem	3150 A	67
6	UNEL 38137-67	630 A	62	4500 A	Comem	4500 A	68
10	UNEL 38137-67	630 A ÷ 1000 A	62	FR 4500	Comem	4500 A	68
20	UNEL 38137-67	2000 A ÷ 3150 A	62	U/6300	Comem	6300 A	69
31	UNEL 38137-67	2000 A ÷ 3150 A	62	L/6300	Comem	6300 A	69
E/1000	UNE 20-176	1000 A	63	TP 5000	Comem	5000 A	70

A₁ – DIN 42530-68 DIN 42539-68 – 1 ÷ 3 kV

250 A ÷ 630 A

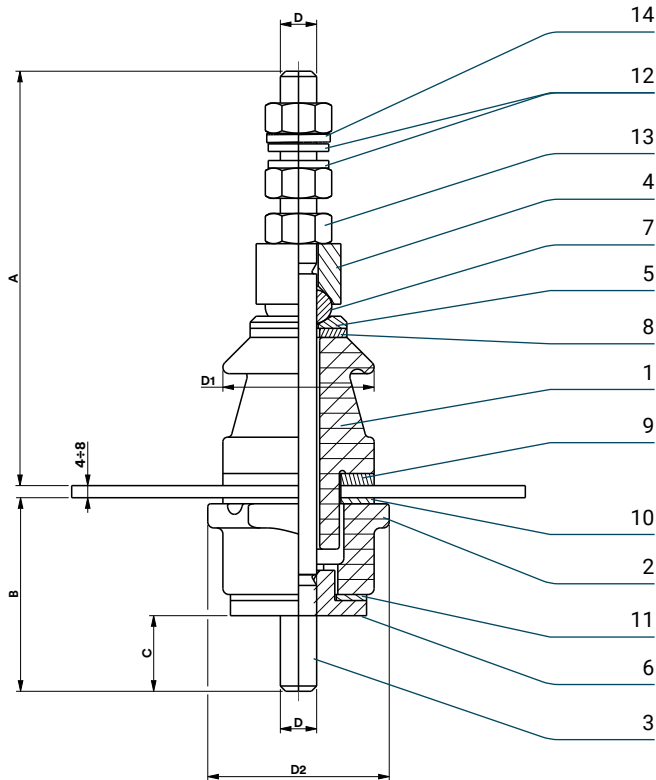

Type	A (Max)	B	C	D	D1	D2	Tank Hole	Weight
1 kV / 250 A	138	68	25	M12	Ø 50	Ø 60	Ø 28	0.7 kg
3 kV / 250 A	180	94	25	M12	Ø 75	Ø 70	Ø 39	1.3 kg
1 kV / 630 A	178	82	37	M20	Ø 70	Ø 85	Ø 45	2.0 kg
3 kV / 630 A	210	110	37	M20	Ø 90	Ø 85	Ø 45	2.5 kg

A₁ – DIN 42530-68 DIN 42539-68 – 1 ÷ 3 kV

250 A ÷ 630 A

Item	Description	Q.ty
1	Upper porcelain	1
2	Lower porcelain	1
3	Bolt	1
4	Upper washer	1
5	Middle washer	1
6	Lower washer	1
7	Gasket	1
8	Gasket	1
9	Gasket	1
10	Gasket	1
11	Gasket	1
12	Washer DIN 125 S	2
13	Full nut	3
14	Washer DIN 127 B	1

Identification			Voltage tightness					
According to standard	Rated voltage (kV)	Rated current (A)	Lighting impulse (kV)	Power frequency (kV)		Creepage distance min. (mm)	Arcing distance min. (mm)	Lee protected line min. (mm)
				Dry	Wet			
DIN 42530-68	1	250	-	-	-	60	50	10
DIN 42539-68	3	250	40	14	10	120	100	16
DIN 42530-68	1	630	-	-	-	75	60	10
DIN 42539-68	3	630	40	14	10	120	100	16

A₂ – DIN 42530-68 DIN 42539-68 – 1 ÷ 3 kV

1000 A ÷ 3150 A

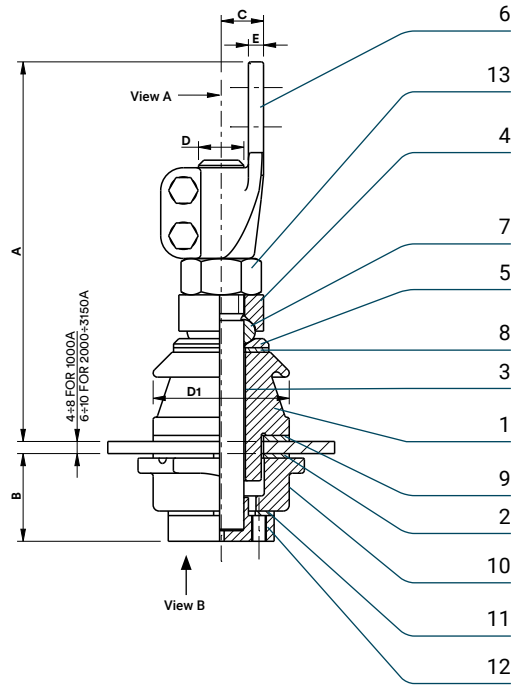

Type	A (Max)	B	C	D	D1	D2	E	Tank Hole	Weight
1 kV/1000 A	263	60	28	M30x2	Ø 90	Ø 110	10	Ø 56	4.9 kg
3 kV/1000 A	294	80	28	M30x2	Ø 110	Ø 110	10	Ø 56	5.8 kg
1 kV/2000 A	340	65	40	M42x3	Ø 104	Ø 125	15	Ø 70	11.7 kg
3 kV/2000 A	372	86	40	M42x3	Ø 125	Ø 125	15	Ø 70	13.0 kg
1 kV/3150 A	372	70	45	M48x3	Ø 125	Ø 150	15	Ø 90	15.8 kg
3 kV/3150 A	404	92	45	M48x3	Ø 145	Ø 150	15	Ø 90	17.5 kg

A₂ – DIN 42530-68 DIN 42539-68 – 1 ÷ 3 kV

1000 A ÷ 3150 A

Item	Description	Q.ty
1	Upper porcelain	1
2	Gasket	1
3	Bolt	1
4	Upper washer	1
5	Middle washer	1
6	Flag DIN 43675	1
7	Gasket	1
8	Gasket	1
9	Gasket	1
10	Lower porcelain	1
11	Gasket	1
12	Lower washer	1
13	Full nut	1
14	Washer DIN 125 A	2
15	Screw DIN 933	2

Identification	Voltage tightness								
	According to standard	Rated voltage (kV)	Rated current (A)	Lighting impulse (kV)	Power frequency (kV)		Creepage distance min. (mm)	Arcing distance min. (mm)	Lee protected line min. (mm)
					Dry	Wet			
DIN 42530-68	1	1000	-	-	-	75	60	10	
DIN 42539-68	3	1000	40	14	10	125	100	16	
DIN 42530-68	1	2000	-	-	-	75	60	10	
DIN 42539-68	3	2000	40	14	10	125	100	18	
DIN 42530-68	1	3150	-	-	-	75	60	10	
DIN 42539-68	3	3150	40	14	10	125	100	18	

View A

1000 A

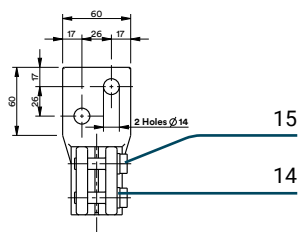

2000 A

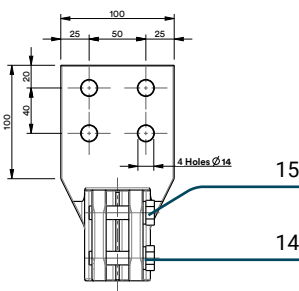

3150 A

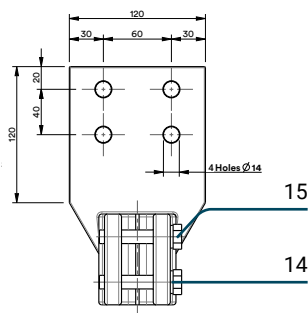

View B

1000 A

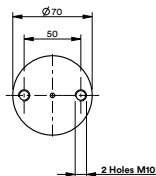

2000 A

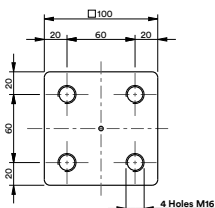

3150 A

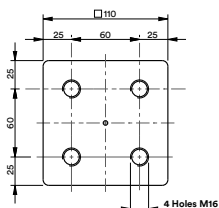

A₃ – EN 50386 – 1 kV

250 A Solution "A"

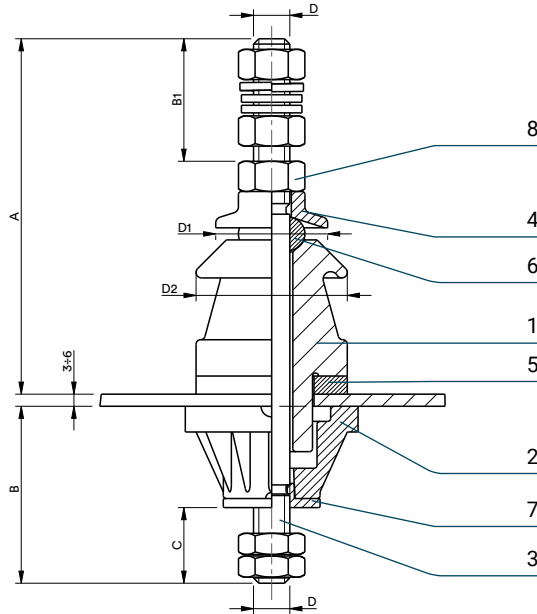

Type	A	B (Max)	B1 (Min)	C	D	D1	D2 (Max)	Tank Hole	Weight
1 kV/250 A	118	58	40	25	M12	Ø 37	Ø 56	Ø 28	0.42 kg

Item	Description	Q.ty	Identification		Voltage tightness						
			According to standard	Rated voltage (kV)	Rated current (A)	Lighting impulse (kV)	Power frequency (kV)	Creepage distance min. (mm)	Arcing distance min. (mm)	Lee protected line min. (mm)	
1	Ceramic body	1	EN 50386	1	250	20	10	10	55	-	-
2	Insulation body	1									
3	Bolt	1									
4	Upper washer	1									
5	Gasket	1									
6	Gasket	1									
7	Lower washer	1									
8	Full nut	1									

A₄ – EN 50386 – 1 kV

250 A Solution “B”

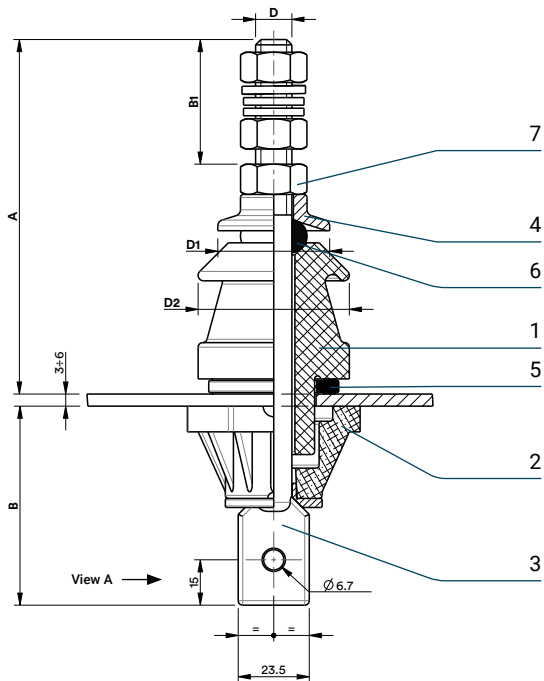

Type	A	B (Max)	B1 (Min)	D	D1	D2 (Max)	Tank Hole	Weight
1 kV/250 A	121	62	40	M12	Ø 37	Ø 56	Ø 28	0.43 kg

Item	Description	Q.ty
1	Ceramic body	1
2	Insulation body	1
3	Bolt "AP" type	1
4	Upper washer	1
5	Gasket	1
6	Gasket	1
7	Full nut	1

Identification According to standard	Voltage tightness		Voltage tightness					
	Rated voltage (kV)	Rated current (A)	Lighting impulse (kV)	Power frequency (kV)		Creepage distance min. (mm)	Arcing distance min. (mm)	Lee protected line min. (mm)
				Dry	Wet			
EN 50386	1	250	20	10	10	55	-	-

View A

250 A

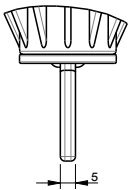

A₅ – EN 50386 – 1 kV

630 A Solution "A"

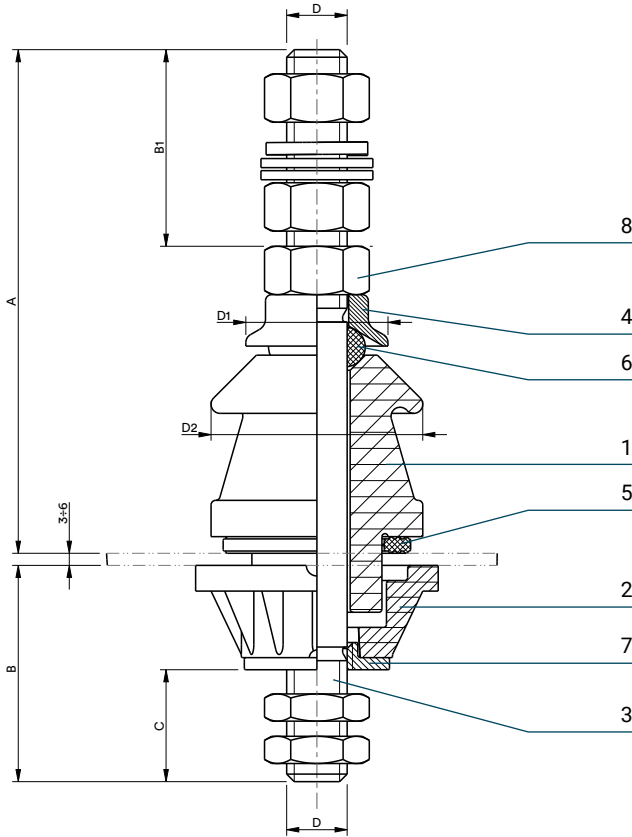

Type	A	B (Max)	B1 (Min)	C	D	D1	D2 (Max)	Tank Hole	Weight
1 kV/630 A	167	71	65	37	M20	Ø 47	Ø 70	Ø 45	1.22 kg

Item	Description	Q.ty	Identification		Voltage tightness						
			According to standard	Rated voltage (kV)	Rated current (A)	Lighting impulse (kV)	Power frequency (kV)	Creepage distance min. (mm)	Arcing distance min. (mm)	Lee protected line min. (mm)	
1	Ceramic body	1	EN 50386	1	630	20	10	10	70	-	-
2	Insulation body	1									
3	Bolt	1									
4	Upper washer	1									
5	Gasket	1									
6	Gasket	1									
7	Lower washer	1									
8	Full nut	1									

A₆ – EN 50386 – 1 kV

630 A Solution "B"

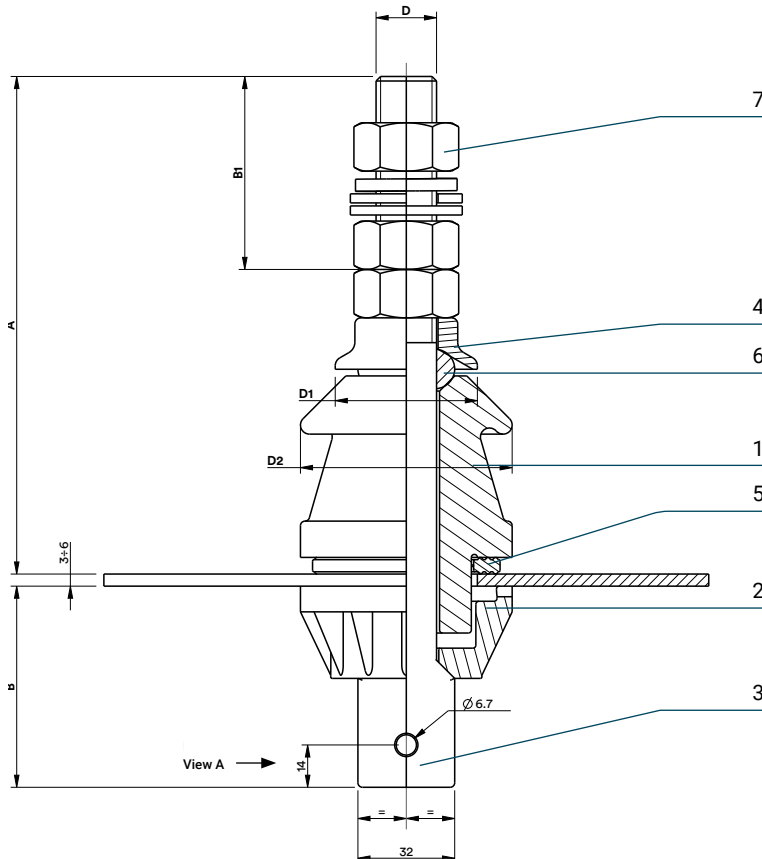

Type	A	B (Max)	B1 (Min)	D	D1	D2 (Max)	Tank Hole	Weight
1 kV/630 A	165	66	65	M20	Ø 47	Ø 70	Ø 45	1.16 kg

A₆ – EN 50386 – 1 kV

630 A Solution “B”

Item	Description	Q.ty
1	Ceramic body	1
2	Insulation body	1
3	Bolt “AP” type	1
4	Upper washer	1
5	Gasket	1
6	Gasket	1
7	Full nut	1

Identification	Voltage tightness								
	According to standard	Rated voltage (kV)	Rated current (A)	Lighting impulse (kV)	Power frequency (kV)		Creepage distance min. (mm)	Arcing distance min. (mm)	Lee protected line min. (mm)
					Dry	Wet			
EN 50386	1	630	20	10	10	70	-	-	

View A

630 A

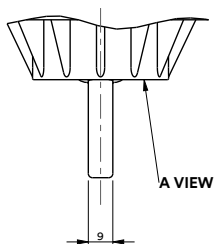

A₇ – EN 50386 – 1 kV

1250 A Solution "A"

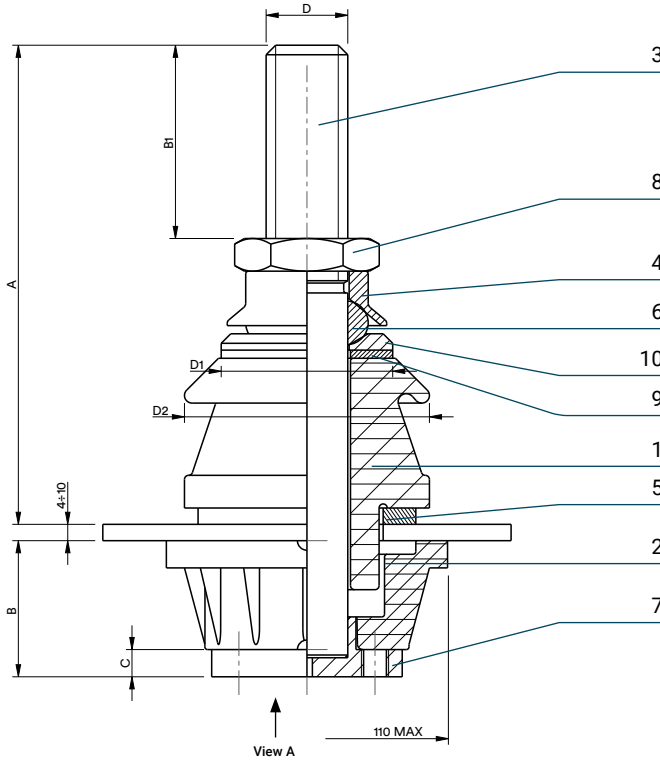

Type	A	B (Max)	B1 (Min)	C	D	D1	D2 (Max)	Tank Hole	Weight
1 kV/1250 A	176	50	70	10	M30x2	Ø 63	Ø 90	Ø 56	2.81 kg

A₇ – EN 50386 – 1 kV

1250 A Solution "A"

Item	Description	Q.ty
1	Ceramic body	1
2	Insulation body	1
3	Bolt	1
4	Upper washer	1
5	Gasket	1
6	Gasket	1
7	Lower washer	1
8	Half nut	1
9	Gasket	1
10	Middle washer	1

Identification	Voltage tightness								
	According to standard	Rated voltage (kV)	Rated current (A)	Lighting impulse (kV)	Power frequency (kV)		Creepage distance min. (mm)	Arcing distance min. (mm)	Lee protected line min. (mm)
					Dry	Wet			
EN 50386	1	1250	20	10	10	75	-	-	

View A

1250 A

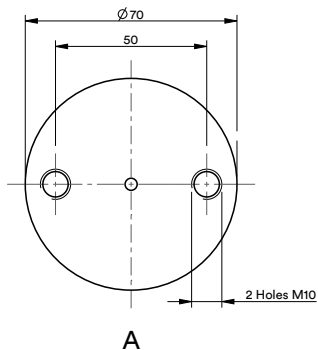

A₈ – EN 50386 – 1 kV

1000 A ÷ 1250 A Solution "B"

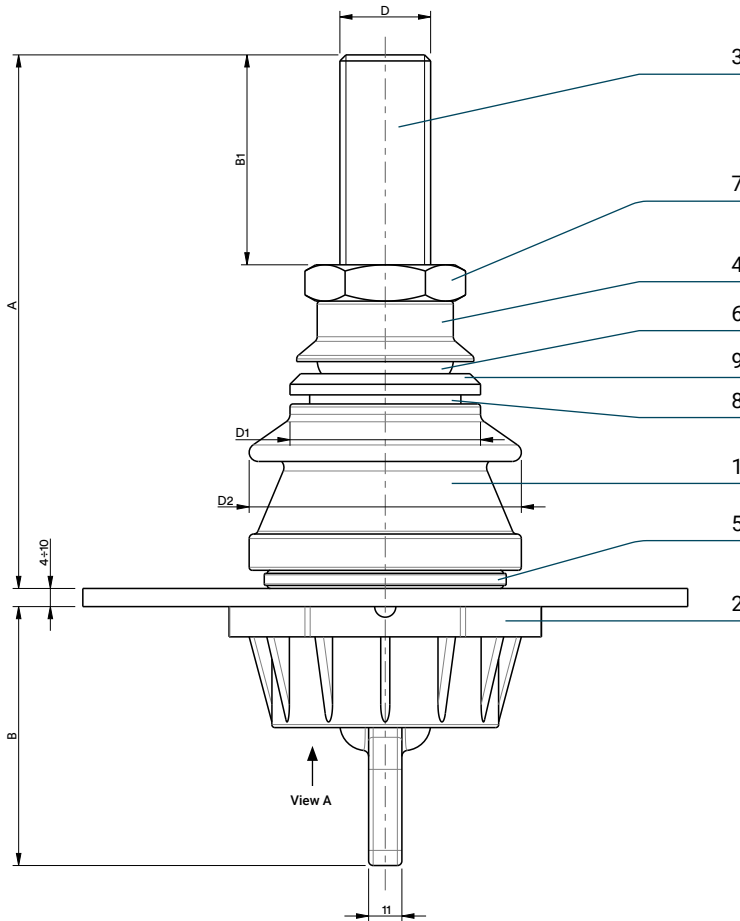

Type	POS. 3 (material)	A (Max)	B (Max)	B1 (Min)	D	D1	D2 (Max)	Tank Hole	Weight
1 kV/1000 A	Brass	177	85	70	M30x2	Ø 63	Ø 90	Ø 56	2.67 kg
1 kV/1250 A	Copper	177	85	70	M30x2	Ø 63	Ø 90	Ø 56	2.73 kg

A₈ – EN 50386 – 1 kV

1000 A ÷ 1250 A Solution “B”

Item	Description	Q.ty	Identification			Voltage tightness					
			According to standard	Rated voltage (kV)	Rated current (A)	Lighting impulse (kV)	Power frequency (kV)		Creepage distance min. (mm)	Arcing distance min. (mm)	Lee protected line min. (mm)
1	Ceramic body	1									
2	Insulation body	1									
3	Bolt “AP” type	1									
4	Upper washer	1									
5	Gasket	1									
6	Gasket	1									
7	Half nut	1									
8	Gasket	1									
9	Middle washer	1									
							Dry	Wet			
			EN 50386	1	1000	20	10	10	75	-	-
			EN 50386	1	1250	20	10	10	75	-	-

View A

1000 A ÷ 1250 A

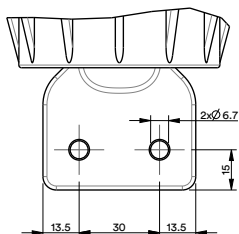

A₉ Type A – EN 50386 – 1 kV

2000 A ÷ 5000 A

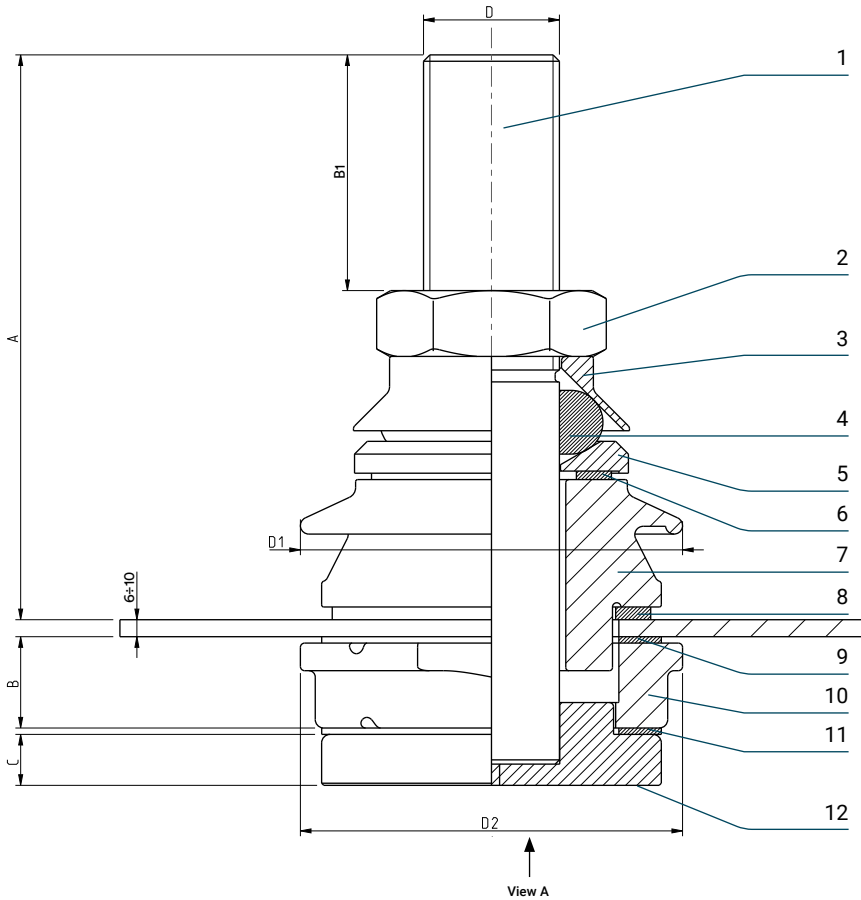

Type	A (Max)	B (Max)	B1 (Min)	C	D	D1 (Max)	D2 (Max)	Tank Hole	Weight
1 kV/2000 A	240	35	90	15	M42x3	Ø 104	Ø 125	Ø 70	6.24 kg
1 kV/3150 A	250	35	90	15	M48x3	Ø 125	Ø 150	Ø 90	8.45 kg
1 kV/4000 A	300	40	110	24	M55x3	Ø 180	Ø 180	Ø 118	16.60 kg
1 kV/5000 A	310	40	110	24	M64x3	Ø 180	Ø 180	Ø 118	18.95 kg

A₉ Type A – EN 50386 – 1 kV

2000 A ÷ 5000 A

Item	Description	Q.ty
1	Bolt	1
2	Half nut	1
3	Upper washer	1
4	Gasket	1
5	Middle washer	1
6	Gasket	1
7	Ceramic body	1
8	Gasket	1
9	Gasket	1
10	Insulation body *	1
11	Gasket	1
12	Lower washer	2

* If polimeric items 9 and 11 are not supplied

Identification According to standard	Identification		Voltage tightness						
	Rated voltage	Rated current	Lighting impulse	Power frequency		Creepage distance min.	Arcing distance min.	Lee protected line min.	
	(kV)	(A)	(kV)	(kV)	(kV)	(mm)	(mm)	(mm)	
				Dry	Wet				
EN 50386	1	2000	20	10	10	75	-	-	
EN 50386	1	3150	20	10	10	75	-	-	
EN 50386	1	4000	20	10	10	85	-	-	
EN 50386	1	5000	20	10	10	85	-	-	

View A

2000 A ÷ 5000 A

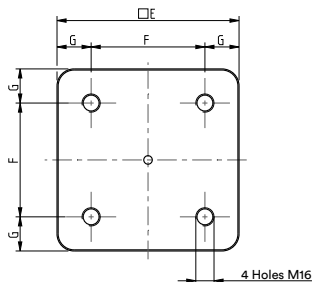

In	E	F	G
2000 A	100	60	20
3150 A	110	60	25
4000 A	160	100	30
5000 A	160	100	30

A₉ Type B – EN 50386 – 1 kV

2000 A

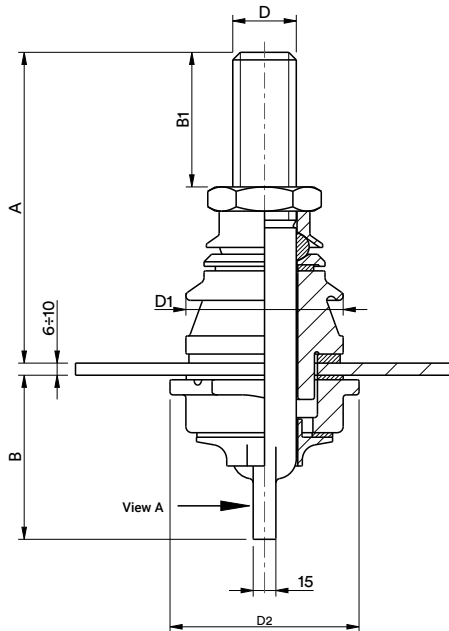

Type	A (Max)	B (Max)	B1 (Min)	C	D	D1 (Max)	D2 (Max)	Tank Hole	Weight
1 kV/2000 A	240	110	90	15	M42x3	Ø 104	Ø 125	Ø 70	6.24 kg

A₉ Type B – EN 50386 – 1 kV

2000 A

Item	Description	Q.ty
1	Bolt	1
2	Half nut	1
3	Upper washer	1
4	Gasket	1
5	Middle washer	1
6	Gasket	1
7	Ceramic body	1
8	Gasket	1
9	Gasket	1
10	Insulation body *	1
11	Gasket	1
12	Lower washer	2

* If polymeric items 9 and 11 are not supplied

Identification	Voltage tightness								
	According to standard	Rated voltage (kV)	Rated current (A)	Lighting impulse (kV)	Power frequency (kV)		Creepage distance min. (mm)	Arcing distance min. (mm)	Lee protected line min. (mm)
					Dry	Wet			
EN 50386	1	2000	20	10	10	75	-	-	

View A

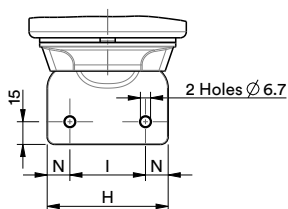

In	H	I	N
2000 A	80	50	15

A₁₀ – COMEM design 3/4500 – 3 kV

4500 A

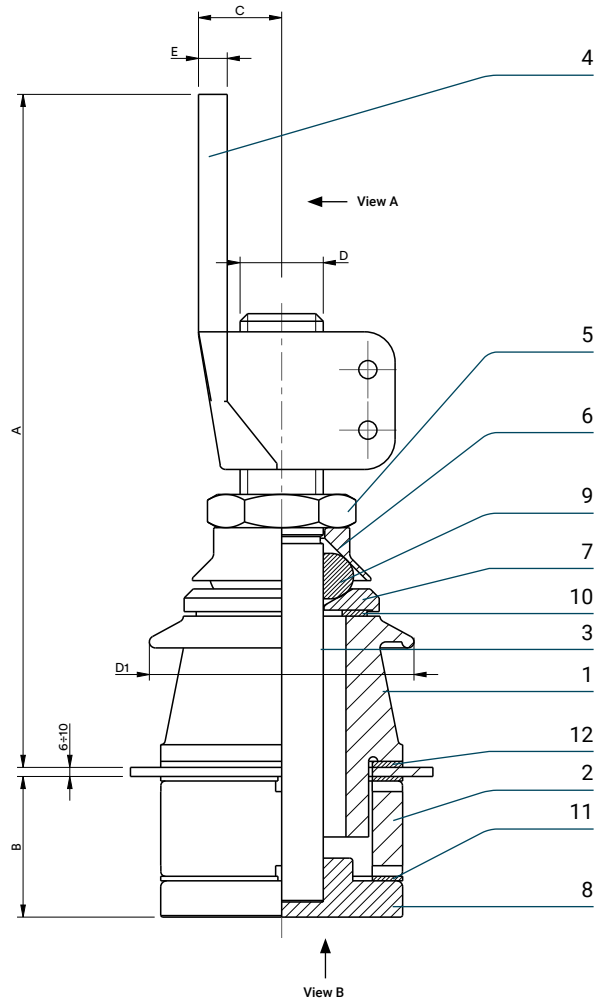

Type	A (Max)	B	C	D	D1	D2	E	Tank Hole	Weight
3 kV/4500 A	453	107	55	M55x3	Ø 175	Ø 160	20	Ø 119	29.8 kg

A₁₀ – COMEM design 3/4500 – 3 kV

4500 A

Item	Description	Q.ty
1	Upper porcelain	1
2	Lower porcelain	1
3	Bolt	1
4	Flag type 4500 A	1
5	Full nut	1
6	Upper washer	1
7	Middle washer	1
8	Lower washer	1
9	Gasket	1
10	Gasket	1
11	Gasket	2
12	Gasket	1

Identification	Voltage tightness							
	Rated voltage	Rated current	Lighting impulse	Power frequency		Arcing distance min.	Arcing distance min.	Lee protected line min.
	(kV)	(A)	(kV)	(kV)	Wet	(mm)	(mm)	(mm)
3/4500	3	4500	40	14	10	140	107	20

View A

4500 A

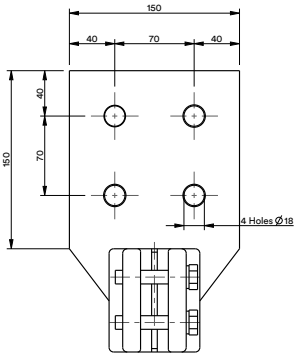

View B

4500 A

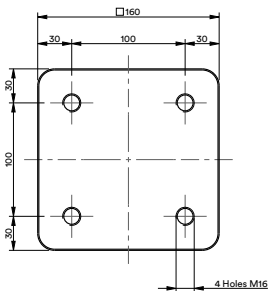

A₁₁ – COMEM design 3/6500 – 3 kV

6500 A

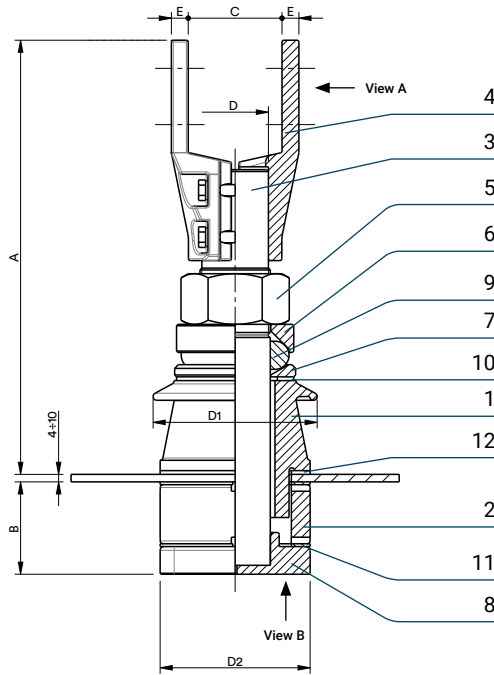

Type	A (Max)	B	C	D	D1	D2	E	Tank Hole	Weight
3 kV/6500 A	463	98.5	100	Ø 71	Ø 175	Ø 160	18	Ø 119	42 kg

A₁₁ – COMEM design 3/6500 – 3 kV

6500 A

Item	Description	Q.ty
1	Upper porcelain	1
2	Lower porcelain	1
3	Bolt	1
4	Semiflag	2
5	Full nut	1
6	Upper washer	1
7	Middle washer	1
8	Lower washer	1
9	Gasket	1
10	Gasket	1
11	Gasket	2
12	Gasket	1
13	Full nut	4
14	Washer DIN 125 A	4
15	Screw DIN 933	4

Identification	Voltage tightness							
	Rated voltage (kV)	Rated current (A)	Lighting impulse (kV)	Power frequency		Creepage distance min. (mm)	Arcing distance min. (mm)	Lee protected line min. (mm)
				Dry	Wet			
3/6500	3	6500	40	14	10	140	107	20

View A

6500 A

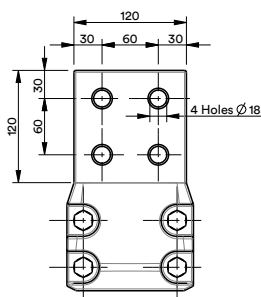

View B

6500 A

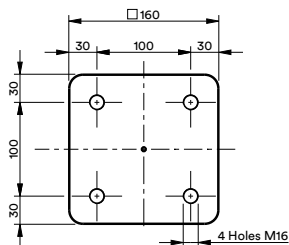

B₁ – DIN 42531-68 – 12 kV ÷ 36 kV

250 A

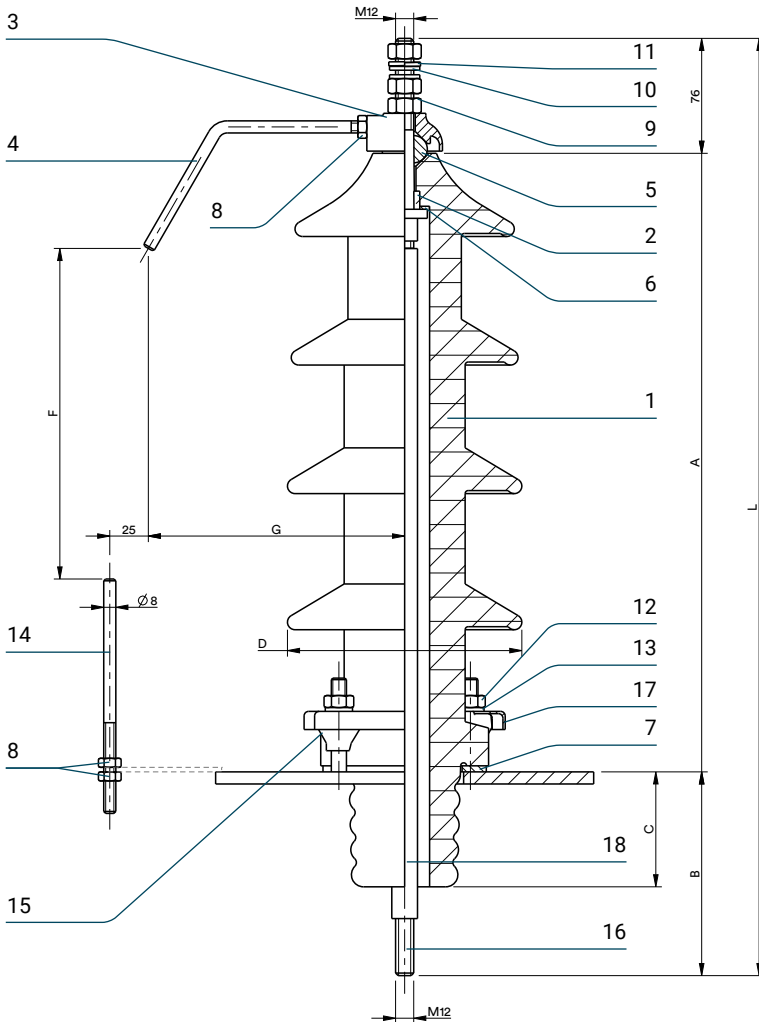

Type	A	B	L	C	D (Max)	F	G	N° of sheds	Tank Hole	Weight
12 kV/250 A	234	120	430	61	Ø 140	85	150	2	Ø 78	4.5 kg
24 kV/250 A	309	135	520	76	Ø 155	155	150	3	Ø 78	6.1 kg
36 kV/250 A	409	135	620	76	Ø 155	220	170	4	Ø 78	7.5 kg

B₁ – DIN 42531-68 – 12 kV ÷ 36 kV

250 A

Item	Description	Q.ty	Identification			Voltage tightness				
			According to standard	Rated voltage (kV)	Rated current (A)	Lighting impulse (kV)	Power frequency (kV)	Creepage distance min. (mm)	Arcing distance min. (mm)	Lee protected line min. (mm)
1	Porcelain	1								
2	Upper bolt	1								
3	Cap	1								
4	Upper horn	1								
5	Gasket	1								
6	Gasket	1								
7	Gasket	1								
8	Full nut	3								
9	Full nut	3								
10	Washer DIN 125 A	2								
11	Washer DIN 127 B	1								
12	Full nut	4								
13	Washer DIN 125 A	4								
14	Lower horn	1								
15	Pressbits	4								
16	Lower bolt	1								
17	Flange	1								
18	Insulating tube	1								

Identification	Rated voltage (kV)	Rated current (A)	Lighting impulse (kV)	Power frequency (kV)		Creepage distance min. (mm)	Arcing distance min. (mm)	Lee protected line min. (mm)
				Dry	Wet			
DIN 42531-68	12	250	75	28	-	305	235	165
DIN 42531-68	24	250	125	50	-	450	310	212
DIN 42531-68	36	250	170	70	-	607	408	288

B₂ – DIN 42532-69 – 12 kV ÷ 36 kV

630 A

Item	Description	Q.ty	Identification		Voltage tightness					
			According to standard	Rated voltage (kV)	Rated current (A)	Lighting impulse (kV)	Power frequency (kV)	Creepage distance min. (mm)	Arcing distance min. (mm)	Lee protected line min. (mm)
1	Porcelain	1								
2	Upper bolt	1								
3	Lower bolt	1								
4	Cap	1								
5	Lower horn	1								
6	Upper horn	1								
7	Gasket	1								
8	Gasket	1								
9	Gasket	1								
10	Full nut	3								
11	Washer DIN 125 A	2								
12	Washer DIN 127 B	1								
13	Full nut	6								
14	Washer DIN 125 A	6								
15	Full nut	3								
16	Flange	1								
17	Pressbits	6								
18	Insulating tube	1								
19	Venting - screw	1								
20	Gasket for venting screw	1								

Identification	Rated voltage (kV)	Rated current (A)	Lighting impulse (kV)	Power frequency (kV)		Creepage distance min. (mm)	Arcing distance min. (mm)	Lee protected line min. (mm)
				Dry	Wet			
DIN 42532-69	12	630	75	28	-	305	230	165
DIN 42532-69	24	630	125	50	-	440	315	245
DIN 42532-69	36	630	170	70	-	662	418	332

B₃ – DIN 42532-69 – 12 kV ÷ 36 kV

1000 A ÷ 3150 A

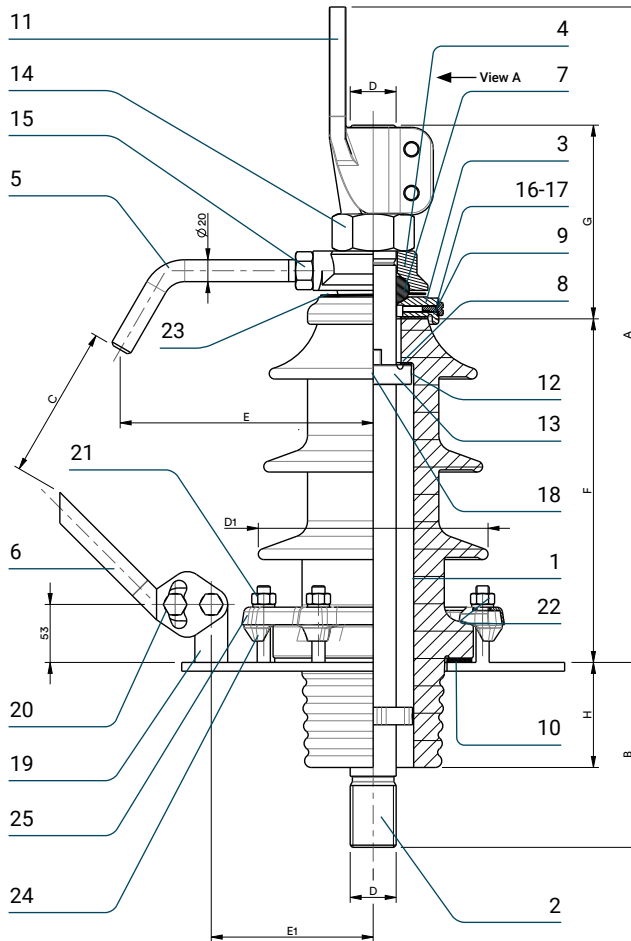

Type	A	B	C	D	D1	E	E1	F	G	H	N° of sheds	Tank Hole	Weight
12 kV/1000 A	455	158	85	M30x2	Ø 170	225	138	239	148	86	2	Ø 110	15 kg
24 kV/1000 A	530	168	155	M30x2	Ø 185	225	138	314	148	96	3	Ø 110	18 kg
36 kV/1000 A	635	198	220	M30x2	Ø 200	285	138	419	148	121	4	Ø 110	22 kg
12 kV/2000 A	530	158	85	M42x3	Ø 190	230	148	239	178	86	2	Ø 135	23 kg
24 kV/2000 A	605	168	155	M42x3	Ø 210	230	148	314	178	96	3	Ø 135	29 kg
36 kV/2000 A	710	198	220	M42x3	Ø 230	290	148	419	178	121	4	Ø 135	35 kg
12 kV/3150 A	550	169	85	M48x3	Ø 190	235	148	239	183	86	2	Ø 135	28.5 kg
24 kV/3150 A	635	178	155	M48x3	Ø 210	235	148	314	183	96	3	Ø 135	32.5 kg
36 kV/3150 A	740	208	220	M48x3	Ø 230	295	148	419	183	121	4	Ø 135	40 kg

B₃ – DIN 42532-69 – 12 kV ÷ 36 kV

1000 A ÷ 3150 A

Item	Description	Q.ty
1	Porcelain	1
2	Bolt	1
3	Cap	1
4	Washer	1
5	Upper horn	1
6	Lower horn	1
7	Gasket	1
8	Gasket	1
9	Gasket	1
10	Gasket	1
11	Flange DIN 43675	1
12	Pressure ring	1
13	Stop ring	1
14	Full nut	1
15	Full nut	1
16	Air screw	1
17	Gasket	1
18	Screw DIN 914	1
19	Support	1
20	Screw DIN 933	2
21	Washer DIN 125 A	8
22	Full nut	8
23	Contact ring	1
24	Pressbits	6
25	Flange	1
26	Screw DIN 933	2

Identification According to standard	Voltage tightness							
	Rated voltage (kV)	Rated current (A)	Lighting impulse (kV)	Power frequency (kV)		Creepage distance min. (mm)	Arcing distance min. (mm)	Lee protected line min. (mm)
				Dry	Wet			
DIN 42533-69	12	1000	75	-	28	295	85	42
DIN 42533-69	24	1000	125	-	50	445	155	90
DIN 42533-69	36	1000	170	-	70	635	220	128
DIN 42533-69	12	2000	75	-	28	295	85	48
DIN 42533-69	24	2000	125	-	50	445	155	90
DIN 42533-69	36	2000	170	-	70	635	220	168
DIN 42533-69	12	3150	75	-	28	295	85	48
DIN 42533-69	24	3150	125	-	50	445	155	90
DIN 42533-69	36	3150	170	-	70	635	220	168

View A

1000 A

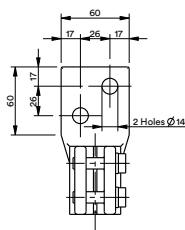

2000 A

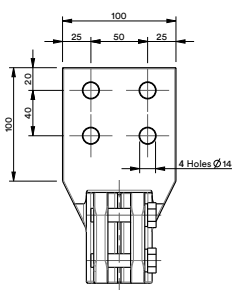

3150 A

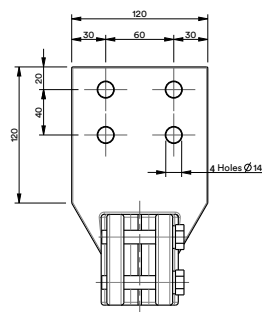

B₄ – DIN 42534-83 – 52 kV

1000 A ÷ 3150 A

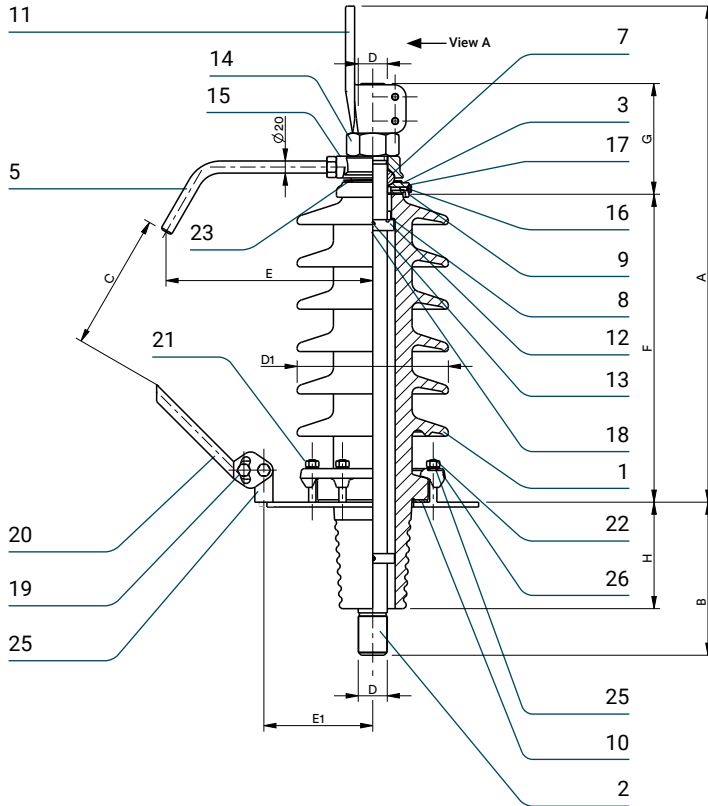

Type	A	B	C	D	D1	E	E1	F	G	H	Tank Hole	Weight
52 kV/1000 A	730	253	305	M30x2	Ø 250	350	175	509	148	176	Ø 135	35.2 kg
52 kV/2000 A	807	253	305	M42x3	Ø 250	350	175	509	178	176	Ø 135	44.9 kg
52 kV/3150 A	836	253	305	M48x3	Ø 250	350	175	509	183	176	Ø 135	49.2 kg

B₄ – DIN 42534-83 – 52 kV

1000 A ÷ 3150 A

Item	Description	Q.ty
1	Porcelain	1
2	Bolt	1
3	Cap	1
4	Washer	1
5	Upper horn	1
6	Lower horn	1
7	Gasket	1
8	Gasket	1
9	Gasket	1
10	Gasket	1
11	Flange DIN 43675	1
12	Pressure ring	1
13	Stop ring	1
14	Full nut	1
15	Full nut	1
16	Air screw	1
17	Gasket	1
18	Screw DIN 914	2
19	Support	1
20	Screw DIN 933	2
21	Washer DIN 125 A	8
22	Full nut	8
23	Contact ring	1
24	Screw DIN 933	2
25	Pressbits	6
26	Flange	1

Identification According to standard	Voltage tightness							
	Rated voltage (kV)	Rated current (A)	Lighting impulse (kV)	Power frequency (kV)	Creepage distance min. (mm)	Arcing distance min. (mm)	Lee protected line min. (mm)	
			Dry		Wet			
DIN 42534-83	52	1000	250	-	95	950	480	340
DIN 42534-83	52	2000	250	-	95	950	480	340
DIN 42534-83	52	3150	250	-	95	950	480	340

View A

1000 A

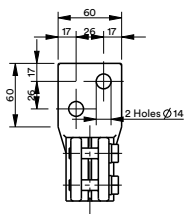

2000 A

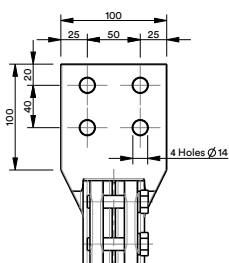

3150 A

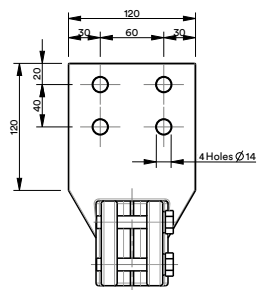

B₅ – CENELEC EN-50180 – 12 kV ÷ 36 kV

250 A

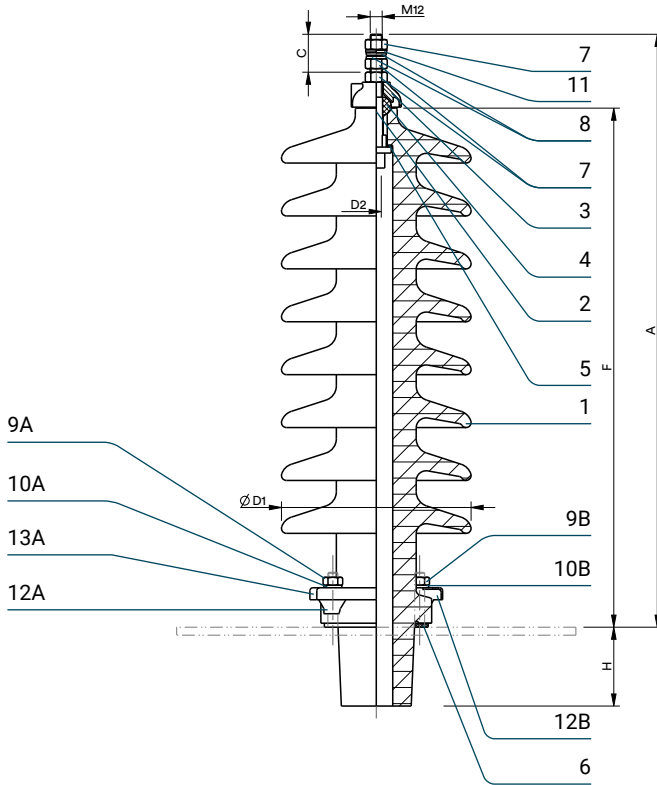

Type	A (Max)	C (Min)	F (Max)	H (Max)	D1 (Max)	D1 (For all)	Insulator type EN 50180	N° of sheds	Tank Hole	Weight
12 kV/250 A-P1	274	45	194	79	Ø 140	Ø 4.5 or Ø 6 or M12	1	2	Ø 80	3.75 kg
12 kV/250 A-P2	274	45	194	79	Ø 140		1	2	Ø 80	
12 kV/250 A-P4	388	45	308	79	Ø 150		2	4	Ø 80	5.65 kg
24 kV/250 A-P2	388	45	308	79	Ø 150		2	4	Ø 80	
24 kV/250 A-P3	441	45	361	79	Ø 155		3	5	Ø 80	6.65 kg
36 kV/250 A-P1	441	45	361	79	Ø 155	3	5	Ø 80		
24 kV/250 A-P4	600	45	520	79	Ø 155	4	8	Ø 80	9.35 kg	
36 kV/250 A-P3	600	45	520	79	Ø 155	4	8	Ø 80		
36 kV/250 A-P4	600	45	520	79	Ø 190	5	8	Ø 80		12.55 kg

B₅ – CENELEC EN-50180 – 12 kV ÷ 36 kV

250 A

With fixation method "A"

Item	Description	Q.ty
1	Porcelain	1
2	Bolt	1
3	Cap	1
4	Gasket	1
5	Gasket	1
6	Gasket	1
7	Full nut	3
8	Washer DIN 125 A	2
9 A	Full nut	4
10 A	Washer DIN 125 A	4
11	Washer	1
12 A	Pressbits	4
13 A	Flange	1

Identification

Voltage tightness

According to standard	Rated voltage (kV)	Rated current (A)	Lighting impulse (kV)	Power frequency (kV)		Creepage distance min. (mm)	Arcing distance min. (mm)	Pollution level
				Dry	Wet			
				EN 50180	12			
EN 50180	12	250	75	-	28	240	145	P2
EN 50180	12	250	75	-	28	372	260	P4
EN 50180	24	250	125	-	50	480	260	P2
EN 50180	24	250	125	-	50	600	315	P3
EN 50180	24	250	125	-	50	744	465	P4
EN 50180	36	250	170	-	70	576	315	P1
EN 50180	36	250	170	-	70	900	465	P3
EN 50180	36	250	170	-	70	1116	485	P4

With fixation method "B"

Item	Description	Q.ty
1	Porcelain	1
2	Bolt	1
3	Cap	1
4	Gasket	1
5	Gasket	1
6	Gasket	1
7	Full nut	3
8	Washer DIN 125 A	2
9 B	Full nut	3
10 B	Washer DIN 125 A	3
11	Washer	1
12 B	Block	3

B₆ – CENELEC EN-50180 – 12 kV ÷ 36 kV

630 A

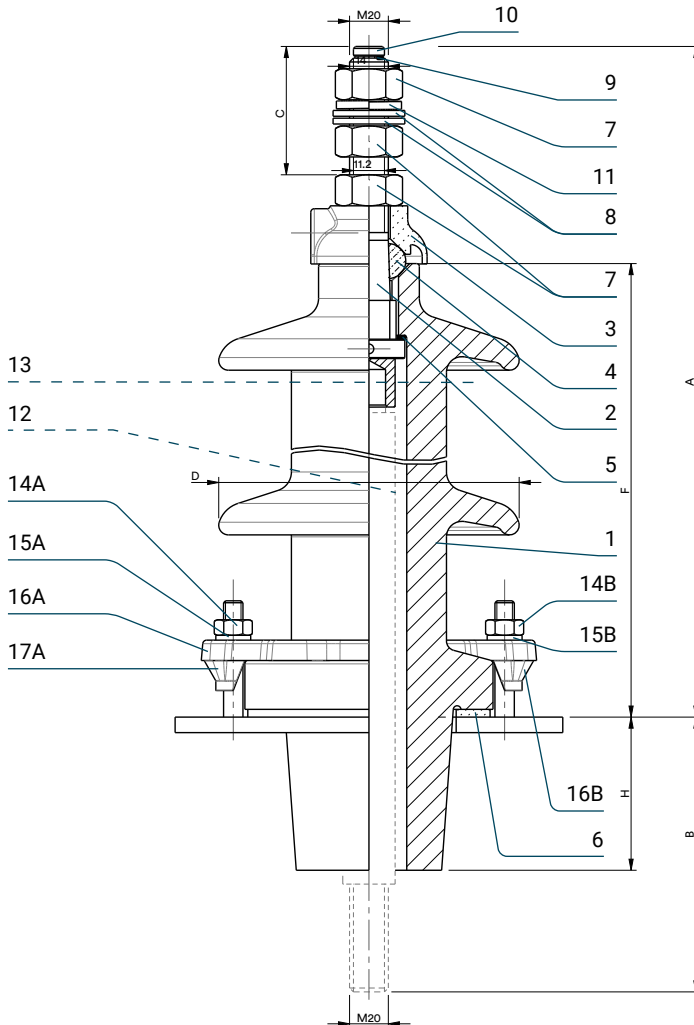

Type	A (Max)	B (Min)	C (Min)	F (Max)	H (Max)	D (Max)	Insulator type	N° of sheds	Tank Hole	Weight
12 kV/630 A - P3	354	149	70	239	79	155	6	2	Ø 90	5.4 kg
12 kV/630 A - P4	444	149	70	329	79	170	7	3	Ø 90	7.1 kg
24 kV/630 A - P2	444	149	70	329	79	170	7	3	Ø 90	7.1 kg
24 kV/630 A - P4	544	149	70	427	79	180	8	5	Ø 90	9.8 kg
36 kV/630 A - P2	544	149	70	427	79	180	8	5	Ø 90	9.8 kg
36 kV/630 A - P4	634	149	70	519	79	210	9	7	Ø 90	15.3 kg

B₆ – CENELEC EN-50180 – 12 kV ÷ 36 kV

630 A

With fixation method "A"

Item	Description	Q.ty
1	Porcelain	1
2	Bolt	1
3	Cap	1
4	Gasket	1
5	Gasket	1
6	Gasket	1
7	Full nut	3
8	Washer DIN 125 A	2
9	Gasket	1
10	Air screw	1
11	Washer	1
12	Insulating tube (to be required)	1
13	Lower bolt (to be required)	1
14 A	Full nut	6
15 A	Washer DIN 125 A	6
16 A	Flange	1
17 A	Pressbits	6

Identification

Voltage tightness

According to standard	Rated voltage (kV)	Rated current (A)	Lighting impulse (kV)	Power frequency		Creepage distance min. (mm)	Arcing distance min. (mm)	Pollution level
				Dry	Wet			
				EN-50180	12			
EN 50180	12	630	75	-	28	372	285	P4
EN 50180	24	630	125	-	50	480	285	P2
EN 50180	24	630	125	-	50	744	375	P4
EN 50180	36	630	170	-	70	720	375	P2
EN 50180	36	630	170	-	70	1116	475	P4

With fixation method "B"

Item	Description	Q.ty
1	Porcelain	1
2	Bolt	1
3	Cap	1
4	Gasket	1
5	Gasket	1
6	Gasket	1
7	Full nut	3
8	Washer DIN 125 A	2
9	Gasket	1
10	Air screw	1
11	Washer	1
12	Insulating tube (to be required)	1
13	Lower bolt (to be required)	1
14 B	Full nut	4
15 B	Washer DIN 125 A	4
16 B	Block	4

B₇ – CENELEC EN-50180 – 12 kV ÷ 36 kV

1250 A ÷ 3150 A

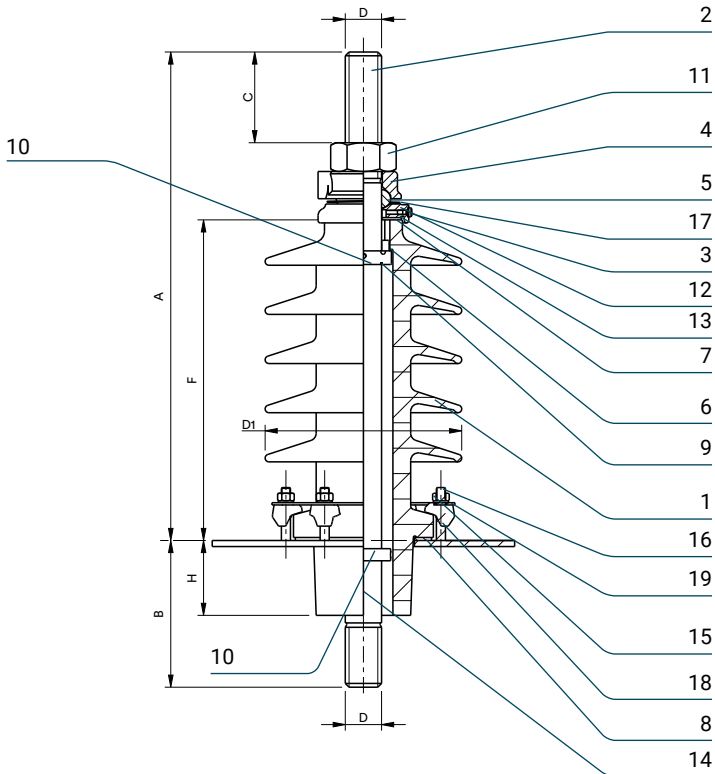

Type	A (Max)	B (Min)	C (Min)	H	F	D (Max) Thread	D1	Insulator type EN 50180	N° of sheds	Tank Hole	Weight
12 kV/1250 A - P4	429	178	80	99	264	M30x2	Ø 210	21	2	Ø 110	12.2 kg
24 kV/1250 A - P3	493	178	80	99	329	M30x2	Ø 210	22	4	Ø 110	13.8 kg
24 kV/1250 A - P4	589	176	80	99	424	M30x2	Ø 240	23	5	Ø 110	15.2 kg
36 kV/1250 A - P3	589	176	80	99	424	M30x2	Ø 240	23	5	Ø 110	15.2 kg
36 kV/1250 A - P4	704	176	80	99	539	M30x2	Ø 240	24	6	Ø 110	16.7 kg
12 kV/2000 A - P4	458	197	100	99	264	M42x3	Ø 230	25	2	Ø 135	19.2 kg
24 kV/2000 A - P3	523	197	100	99	329	M42x3	Ø 230	26	4	Ø 135	25.1 kg
24 kV/2000 A - P4	622	193	100	99	424	M42x3	Ø 260	27	5	Ø 135	30.3 kg
36 kV/2000 A - P3	622	193	100	99	424	M42x3	Ø 260	27	5	Ø 135	30.3 kg
36 kV/2000 A - P4	733	197	100	99	539	M42x3	Ø 260	28	6	Ø 135	32.6 kg
12 kV/3150 A - P4	484	196	120	99	264	M48x3	Ø 230	25	2	Ø 135	22.1 kg
24 kV/3150 A - P3	549	196	120	99	329	M48x3	Ø 230	26	4	Ø 135	29.1 kg
24 kV/3150 A - P4	646	194	120	99	424	M48x3	Ø 260	27	5	Ø 135	31.9 kg
36 kV/3150 A - P3	646	194	120	99	424	M48x3	Ø 260	27	5	Ø 135	31.9 kg
36 kV/3150 A - P4	761	194	120	99	539	M48x3	Ø 260	28	6	Ø 135	33.8 kg

B₇ – CENELEC EN-50180 – 12 kV ÷ 36 kV

1250 A ÷ 3150 A

Item	Description	Q.ty	Identification		Voltage tightness					
			According to standard	Rated voltage (kV)	Rated current (A)	Lighting impulse (kV)	Power frequency (kV)	Creepage distance min. (mm)	Arcing distance min. (mm)	Pollution level
1	Porcelain	1								
2	Bolt	1								
3	Cap	1								
4	Washer	1								
5	Gasket	1								
6	Gasket	1	EN 50180	12	2000	75	- 28	372	210	P4
7	Gasket	1	EN 50180	12	3150	75	- 28	372	210	P4
8	Gasket	1	EN 50180	24	1250	125	- 50	600	280	P3
9	Stop ring	1	EN 50180	24	1250	125	- 50	744	385	P4
10	Pressure ring	2	EN 50180	24	2000	125	- 50	600	275	P3
11	Full nut	1	EN 50180	24	2000	125	- 50	744	385	P4
12	Air screw	1	EN 50180	24	3150	125	- 50	600	275	P3
13	Gasket	1	EN 50180	24	3150	125	- 50	744	385	P4
14	Screw DIN 914	4	EN 50180	36	1250	170	- 70	900	385	P3
15	Full nut	6	EN 50180	36	1250	170	- 70	1116	500	P4
16	Flange	1	EN 50180	36	2000	170	- 70	900	385	P3
17	Contact ring	1	EN 50180	36	2000	170	- 70	1116	495	P4
18	Pressbits	6	EN 50180	36	3150	170	- 70	900	385	P3
19	Washer DIN 125 A	6	EN 50180	36	3150	170	- 70	1116	495	P4

B₈ – CENELEC EN-50180 – 52 kV

1250 A ÷ 3150 A

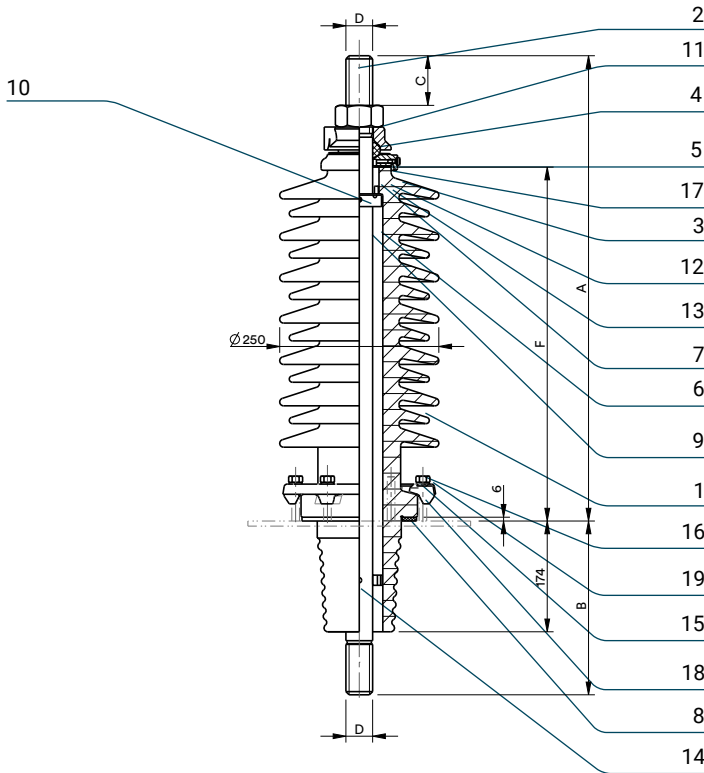

Type	A	B	C	D	F	N° of sheds	Tank Hole	Weight
52 kV/1250A-P1	655	260	65	M30x2	511	6	Ø 135	35.2 kg
52 kV/2000A-P1	685	270	85	M42x3	511	6	Ø 135	44.9 kg
52 kV/3150A-P1	690	280	85	M48x3	511	6	Ø 135	49.2 kg
52 kV/1250A-P3	655	260	65	M30x2	511	11	Ø 135	37.5 kg
52 kV/2000A-P3	685	270	85	M42x3	511	11	Ø 135	47.5 kg
52 kV/3150A-P3	690	280	85	M48x3	511	11	Ø 135	51.9 kg
52 kV/1250A-P4	700	260	65	M30x2	556	13	Ø 135	40.0 kg
52 kV/2000A-P4	730	270	85	M42x3	556	13	Ø 135	50.5 kg
52 kV/3150A-P4	735	280	85	M48x3	556	13	Ø 135	54.5 kg

B₈ – CENELEC EN-50180 – 52 kV

1250 A ÷ 3150 A

Item	Description	Q.ty	Identification			Voltage tightness				
			According to standard	Rated voltage (kV)	Rated current (A)	Lighting impulse (kV)	Power frequency (kV)	Creepage distance min. (mm)	Arcing distance min. (mm)	Pollution level
1	Porcelain	1								
2	Bolt	1								
3	Cap	1								
4	Washer	1								
5	Gasket	1								
6	Gasket	1	EN 50180	52	2000	250	- 95	832	480	P1
7	Gasket	1	EN 50180	52	3150	250	- 95	832	480	P1
8	Gasket	1	EN 50180	52	1250	250	- 95	1300	480	P3
9	Stop ring	1	EN 50180	52	2000	250	- 95	1300	480	P3
10	Pressure ring	2	EN 50180	52	3150	250	- 95	1300	480	P3
11	Full nut	1	EN 50180	52	1250	250	- 95	1612	520	P4
12	Air screw	1	EN 50180	52	2000	250	- 95	1612	520	P4
13	Gasket	1	EN 50180	52	3150	250	- 95	1612	520	P4
14	Screw DIN 914	4								
15	Full nut	6								
16	Flange	1								
17	Contact ring	1								
18	Pressbits	6								
19	Washer DIN 125 A	6								

B₉ – COMEM design 36/250 A – 36 kV

250 A

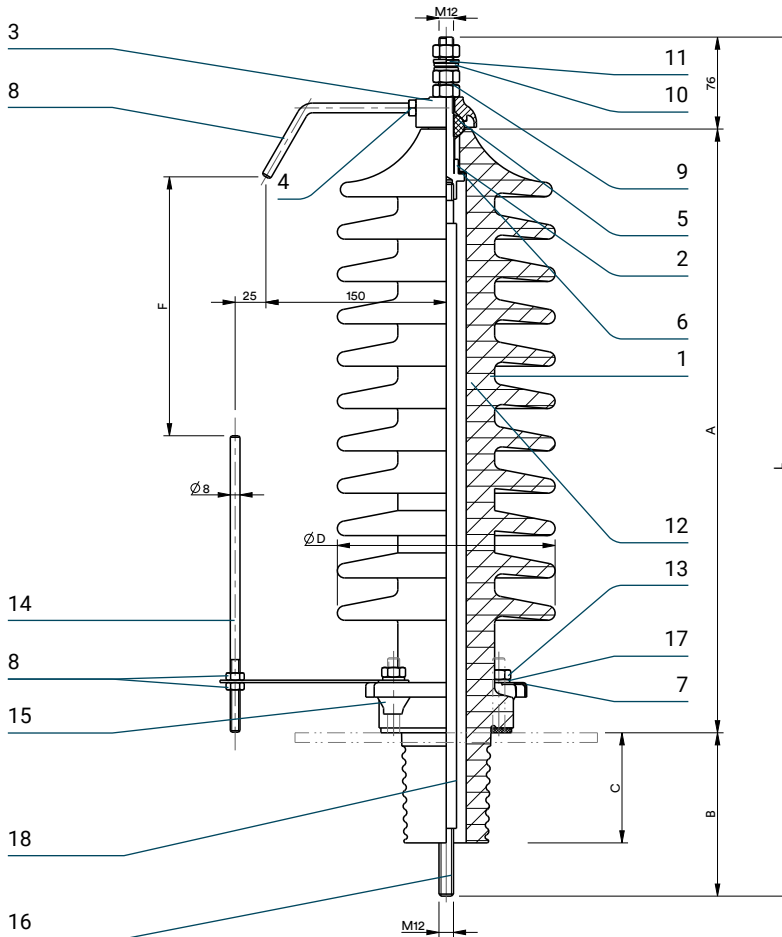

Type	A	B	L	C	D	F	N° of sheds	Tank Hole	Weight
C. D. 1320	499	135	710	91	Ø 180	220	11	Ø 78	10.2 kg

B₉ – COMEM design 36/250 A – 36 kV

250 A

Item	Description	Q.ty
1	Porcelain	1
2	Upper bolt	1
3	Cap	1
4	Upper horn	1
5	Gasket	1
6	Gasket	1
7	Gasket	1
8	Full nut	3
9	Full nut	3
10	Washer DIN 125 A	2
11	Washer DIN 127 B	1
12	Full nut	4
13	Washer DIN 125 A	4
14	Lower horn	1
15	Pressbits	4
16	Lower bolt	1
17	Flange	1
18	Insulating tube	1

Identification	Voltage tightness							
	Rated voltage	Rated current	Lighting impulse	Power frequency	Creepage distance min.	Arcing distance min.	Lee protected line min.	
	(kV)	(A)	(kV)	(kV)	(mm)	(mm)	(mm)	
				Dry	Wet			
36/250	36	250	170	70	-	1320	-	-

B₁₀ – COMEM design 52/250-630 A – 52 kV

250 A ÷ 630 A

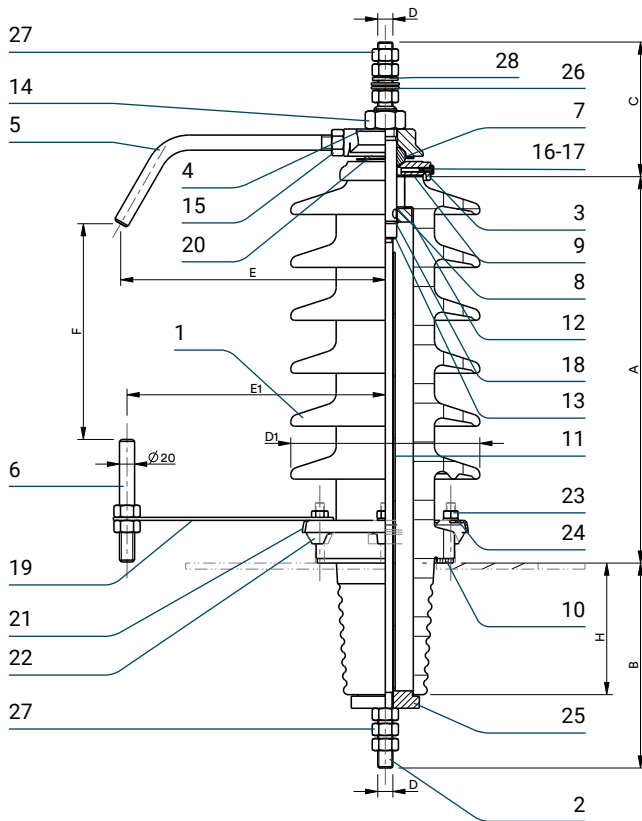

Type	Pos. 2-13	A (Max)	B (Min)	C (Min)	D	D1	E	E1	F	H	N° of sheds	Tank Hole	Weight
52 kV/250 A	Brass	511	258	60	M12	Ø 250	350	340	250	174	6	Ø 135	24.4 kg
52 kV/630 A	Copper	511	270	85	M20	Ø 250	350	340	250	174	6	Ø 135	26.4 kg

B₁₀ – COMEM design 52/250-630 A – 52 kV

250 A ÷ 630 A

Item	Description	Q.ty	Identification		Voltage tightness					
			COMEM design	Rated voltage (kV)	Rated current (A)	Lighting impulse (kV)	Power frequency (kV)	Creepage distance min. (mm)	Arcing distance min. (mm)	Lee protected line min. (mm)
1	Porcelain	1								
2	Lower bolt	1								
3	Cap	1								
4	Washer	1								
5	Upper horn	1								
6	Lower horn	1								
7	Gasket	1								
8	Gasket	1								
9	Gasket	1								
10	Gasket	1								
11	Insulating tube	1								
12	Pressure ring	1								
13	Upper bolt	1								
14	Full nut	1								
15	Full nut	3								
16	Air screw	1								
17	Gasket	1								
18	Screw DIN 914	1								
19	Support	2								
20	Contact ring	1								
21	Flange	1								
22	Pressbits	1								
23	Full nut	6								
24	Washer DIN 125 A	6								
25	Center ring	1								
26	Washer DIN 125 A	2								
27	Full nut	6								
28	Washer DIN 127 B	1								
			52/250	52	250	250	- 95	950	480	340
			52/630	52	630	250	- 95	950	480	340

B₁₁ – COMEM design 24/6300 A – 24 kV

6300 A

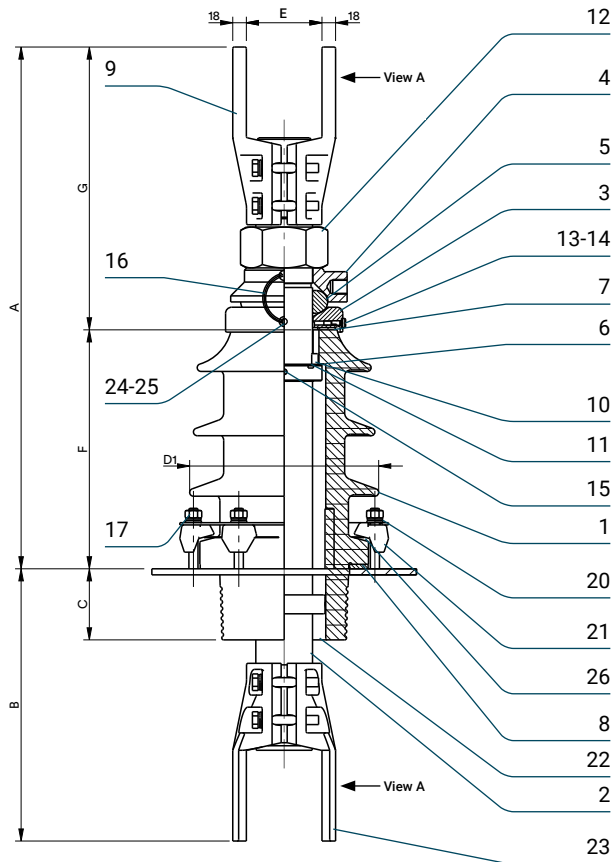

Type	A	B	C	D1	E	F	G	N° of sheds	Tank Hole	Weight
24 kV/6300 A	690	360	94	Ø 250	100	316	380	3	Ø 176	48 kg

B₁₁ – COMEM design 24/6300 A – 24 kV

6300 A

Item	Description	Q.ty
1	Porcelain	1
2	Bolt	1
3	Cap	1
4	Washer	1
5	Gasket	1
6	Gasket	1
7	Gasket	1
8	Gasket	1
9	Upper flag	1
10	Pressure ring	1
11	Stop ring	1
12	Full nut	1
13	Air screw	1
14	Gasket	1
15	Screw DIN 914	3
16	Cable lead	1
17	Full nut	1
18	Washer DIN 125 A	1
19	Washer	2
20	Flange	1
21	Pressbits	1
22	Center ring	1
23	Lower flag	6
24	Screw	6
25	Washer DIN 125 A	1
26	Ring of compensation	2
27	Screw DIN 933	1

Identification	Voltage tightness							
	Rated voltage	Rated current	Lighting impulse	Power frequency	Creepage distance min.	Arcing distance min.	Lee protected line min.	
	(kV)	(A)	(kV)	(kV)	(mm)	(mm)	(mm)	
24/6300	24	6300	125	-	50	440	155	90

View A

6300 A

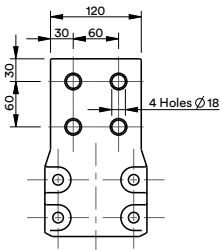

B₁₂ – COMEM design 12-36/4500 A – 12 ÷ 36 kV

4500 A

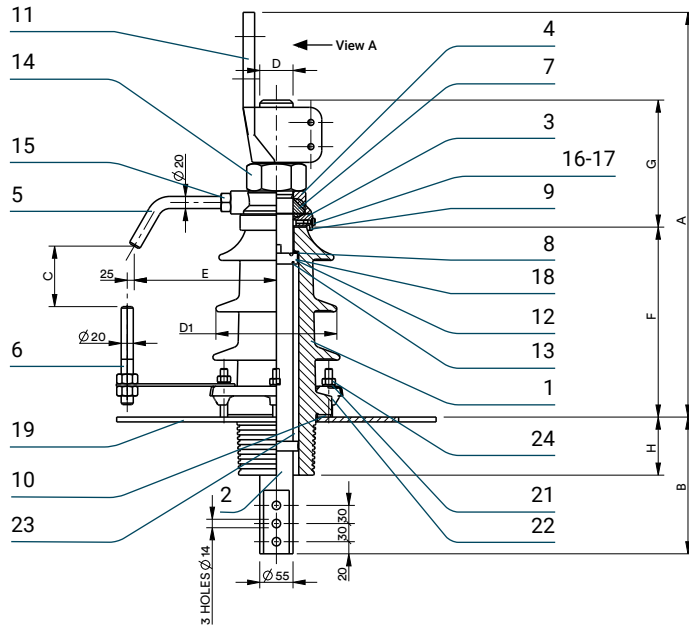

Type	A	B	C	D	D1 (max)	E	F	G	H	N° of sheds	Tank Hole	Weight
12 kV/4500 A	600	218	70	M55x3	Ø 190	235	239	210	86	2	Ø 135	36 kg
24 kV/4500 A	675	226	100	M55x3	Ø 210	235	314	210	96	3	Ø 135	40 kg
36 kV/4500 A	780	253	130	M55x3	Ø 230	235	419	210	121	4	Ø 135	46 kg

B₁₂ – COMEM design 12-36/4500 A – 12 ÷ 36 kV

4500 A

Item	Description	Q.ty	Identification		Voltage tightness				
			COMEM design	Rated voltage (kV)	Rated current (A)	Lighting impulse (kV)	Power frequency (kV)	Creepage distance min. (mm)	Arcing distance min. (mm)
1	Porcelain	1							
2	Bolt	1							
3	Cap	1							
4	Washer	1							
5	Upper horn	1							
6	Lower horn	1							
7	Gasket	1							
8	Gasket	1							
9	Gasket	1							
10	Gasket	1							
11	Flag type 4500 A	1							
12	Pressure ring	1							
13	Stop ring	1							
14	Full nut	1							
15	Full nut	3							
16	Air screw	1							
17	Gasket	1							
18	Screw DIN 914	2							
19	Support	1							
20	Cable lead	1							
21	Flange	1							
22	Pressbits	6							
23	Center ring	1							
24	Full nut	6							
25	Washer DIN 125 A	8							
26	Screw DIN 933	2							
27	Washer DIN 125 A	2							
28	Washer DIN 127 B	2							
29	Screw	2							

COMEM design	Rated voltage (kV)	Rated current (A)	Lighting impulse (kV)	Power frequency (kV)		Creepage distance min. (mm)	Arcing distance min. (mm)	Lee protected line min. (mm)
				Dry	Wet			
12/4500	12	4500	75	-	28	295	85	48
24/4500	24	4500	125	-	50	445	155	90
36/4500	36	4500	170	-	70	635	220	168

View A

4500 A

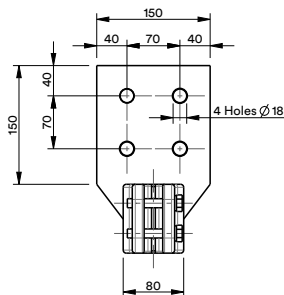

B₁₃ – COMEM design special creepage distance 1430 mm – 52 kV

1000 A ÷ 3150 A

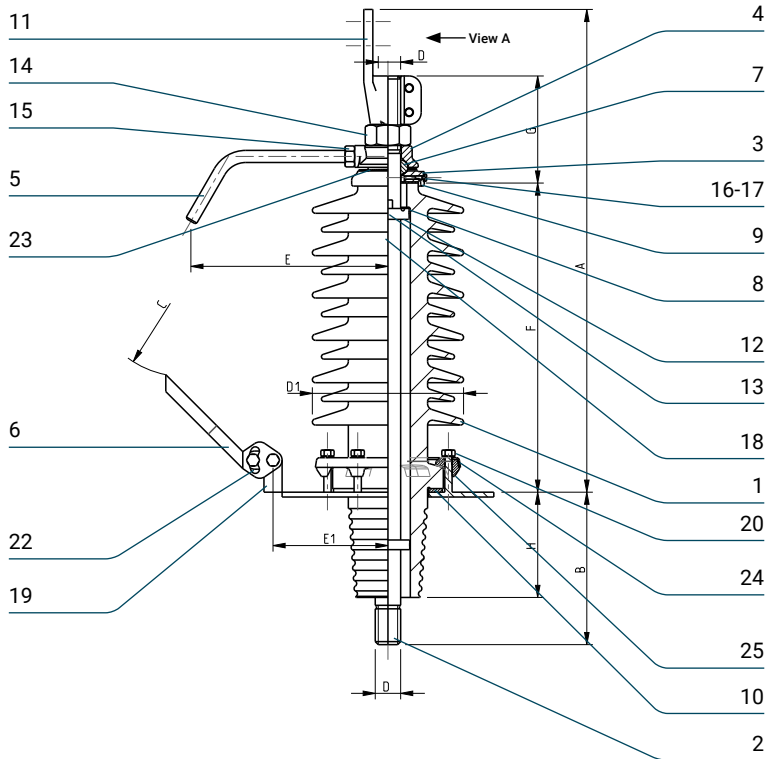

Type	A	B	C	D	D1	E	E1	F	G	H	N° of sheds	Tank Hole	Weight
52 kV/1000 A	730	251	305	M30x2	Ø 250	350	175	511	148	176	11	Ø 135	35.2 kg
52 kV/2000 A	807	251	305	M42x3	Ø 250	350	175	511	178	176	11	Ø 135	44.9 kg
52 kV/3150 A	836	251	305	M48x3	Ø 250	355	180	511	183	176	11	Ø 135	49.2 kg

B₁₃ – COMEM design special creepage distance 1430 mm – 52 kV

1000 A ÷ 3150 A

Item	Description	Q.ty
1	Porcelain	1
2	Bolt	1
3	Cap	1
4	Washer	1
5	Upper horn	1
6	Lower horn	1
7	Gasket	1
8	Gasket	1
9	Gasket	1
10	Gasket	1
11	Flange DIN 43675	1
12	Pressure ring	1
13	Stop ring	1
14	Full nut	1
15	Full nut	1
16	Air screw	1
17	Gasket	1
18	Screw DIN 914	2
19	Support	1
20	Full nut	8
21	Washer DIN 125 A	8
22	Screw DIN 933	2
23	Contact ring	1
24	Flange	1
25	Pressbits	6
26	Screw DIN 933	2

COMEM design	Voltage tightness							
	Rated voltage	Rated current	Lighting impulse	Power frequency	Creepage distance min.	Arcing distance min.	Lee protected line min.	
	(kV)	(A)	(kV)	(kV)	(mm)	(mm)	(mm)	
				Dry	Wet			
-	52	1000	250	-	95	1430	480	340
-	52	2000	250	-	95	1430	480	340
-	52	3150	250	-	95	1430	480	340

View A

1000 A

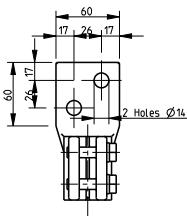

2000 A

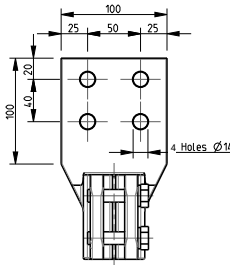

3150 A

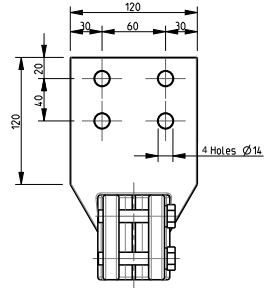

B₁₄ – DIN 42541-83 – 24 ÷ 36 kV

5000 A ÷ 8000 A

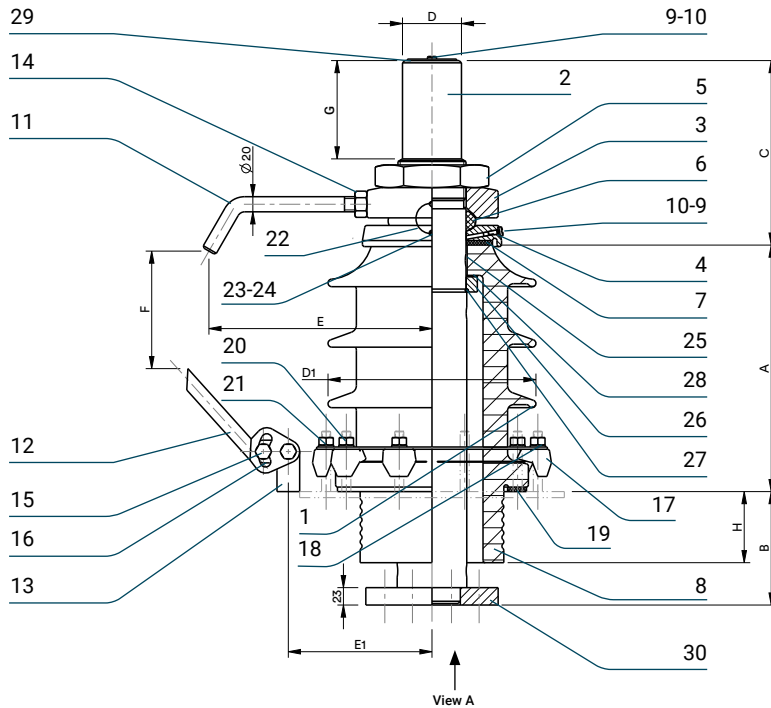

Type	A	B	C	D	D1	E	E1	F	H	G	N° of sheds	Tank Hole	Weight
24 kV/5000 A	326	150	214	Ø 78	Ø 275	295	190	155	94	100	3	Ø 200	52.5 kg
36 kV/5000 A	421	175	214	Ø 78	Ø 280	320	190	220	119	100	4	Ø 200	56.5 kg
24 kV/8000 A	326	150	214	Ø 78	Ø 275	295	190	155	94	130	3	Ø 200	54 kg
36 kV/8000 A	421	175	214	Ø 78	Ø 280	320	190	220	119	130	4	Ø 200	58 kg

B₁₄ – DIN 42541-83 – 24 ÷ 36 kV

5000 A ÷ 8000 A

Item	Description	Q.ty
1	Porcelain	1
2	Bolt	1
3	Washer	1
4	Cap	1
5	Nut	1
6	Gasket	1
7	Gasket	1
8	Gasket	1
9	Air screw	2
10	Gasket	2
11	Upper horn	1
12	Lower horn	1
13	Support	1
14	Full nut	1
15	Screw DIN 914	2
16	Washer DIN 125 A	2
17	Pressbits	10
18	Flange	1
19	Ring of compensation	1
20	Full nut	12
21	Washer DIN 125 A	10
22	Cable lead	1
23	Washer DIN 125 A	2
24	Screw	2
25	Pin	1
26	Pressure ring	1
27	Stop ring	1
28	Gasket	1
29	Copper disc	1
30	Lower washer	1

Identification According to standard	Voltage tightness							
	Rated voltage (kV)	Rated current (A)	Lighting impulse (kV)	Power frequency (kV)		Creepage distance min. (mm)*	Arcing distance min. (mm)*	Lee protected line min. (mm)
				Dry	Wet			
DIN 42541-83	24	5000	125	-	50	470	260	105
DIN 42541-83	36	5000	170	-	70	555	355	140
DIN 42541-83	24	8000	125	-	50	470	260	105
DIN 42541-83	36	8000	170	-	70	555	355	140

* Data reported from DIN 42541

View A

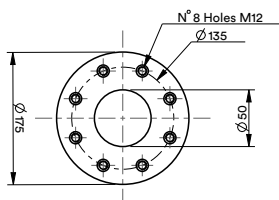

B₁₅ – EN 50243 – 24 ÷ 36 kV

5000 A ÷ 8000 A

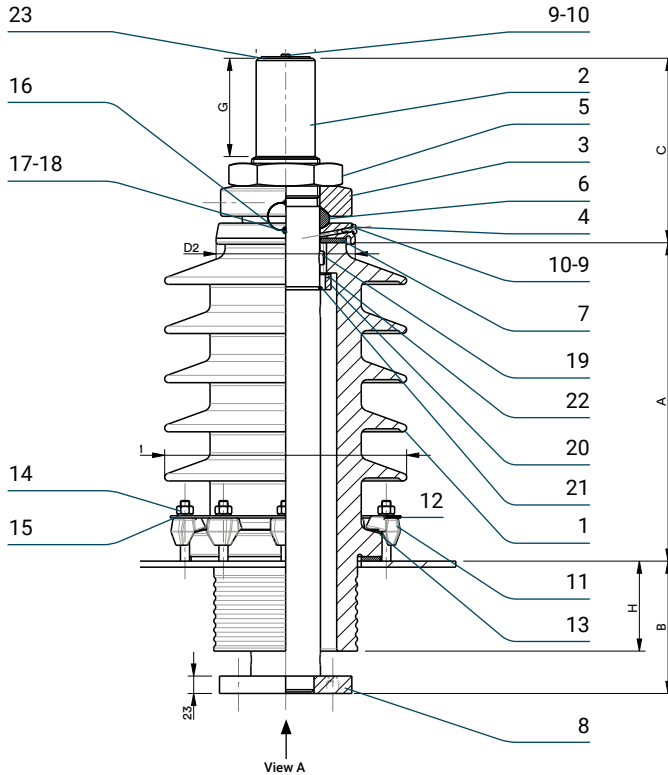

Type	A	B	C	D	D1	D2	H	G	Insulator type	N° of sheds	Tank Hole	Weight
24 kV/5000 A-P2	326	150	214	Ø 78	Ø 285	Ø 184	94	100	24-P2	3	Ø 200	66.5 kg
24 kV/8000 A-P2	326	150	244	Ø 78	Ø 285	Ø 184	94	130	24-P2	3	Ø 200	68 kg
24 kV/5000 A-P4	421	175	214	Ø 78	Ø 320	Ø 184	119	100	36-P2	5	Ø 200	81 kg
24 kV/8000 A-P4	421	175	244	Ø 78	Ø 320	Ø 184	119	130	36-P2	5	Ø 200	82.5 kg
36 kV/5000 A-P2	421	175	214	Ø 78	Ø 320	Ø 184	119	100	36-P2	5	Ø 200	81 kg
36 kV/8000 A-P2	421	175	244	Ø 78	Ø 320	Ø 184	119	130	36-P2	5	Ø 200	82.5 kg
36 kV/5000 A-P3	421	175	214	Ø 78	Ø 295	Ø 184	119	100	36-P3	9	Ø 200	83.5 kg
36 kV/8000 A-P3	421	175	244	Ø 78	Ø 295	Ø 184	119	130	36-P3	9	Ø 200	85 kg

B₁₅ – EN 50243 – 24 ÷ 36 kV

5000 A ÷ 8000 A

Item	Description	Q.ty	Identification	Voltage tightness								
				Rated voltage (kV)	Rated current (A)	Lighting impulse (kV)	Power frequency (kV)	Creepage distance min. (mm)*	Arcing distance min. (mm)*	Lee protected line min. (mm)	Pollution level	
1	Porcelain	1										
2	Bolt	1										
3	Washer	1										
4	Cap	1										
5	Nut	1										
6	Gasket	1										
7	Gasket	1										
8	Gasket	1										
9	Air screw	1										
10	Gasket	1										
11	Pressbits	10										
12	Flange	1										
13	Ring of compensation	1										
14	Nut	10										
15	Washer DIN 125 A	10										
16	Cable lead	1										
17	Washer DIN 125 A	2										
18	Screw	2										
19	Pin	1										
20	Pressure ring	1										
21	Stop ring	1										
22	Gasket	1										
23	Copper disc	1										
24	Lower washer	1										

* Data reported from EN 50243

View A

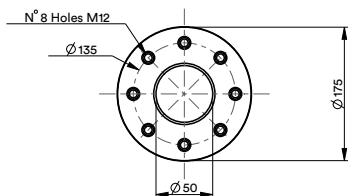

Connecting flags for bushings

C – DIN 43675-75

630 A

DP Type

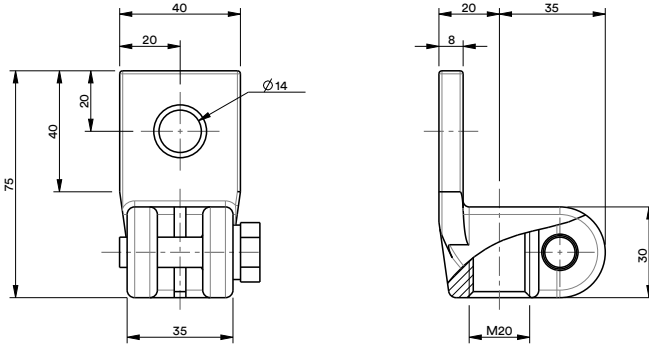

Item	Description	Q.ty
1	Flag DP	1
2	Washer DIN 125 A	1
3	Screw DIN 933	1

DR Type

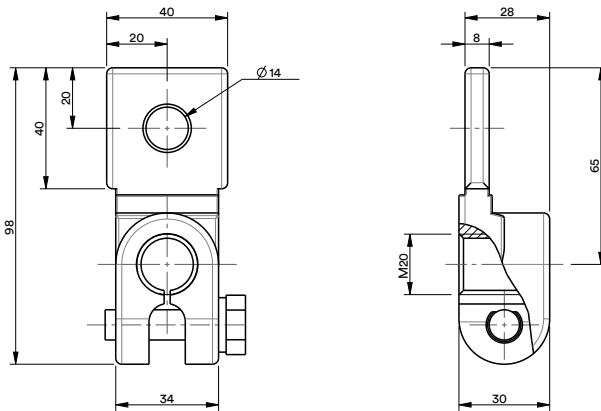

Item	Description	Q.ty
1	Flag DR	1
2	Washer DIN 125 A	1
3	Screw DIN 933	1

C – DIN 43675-75

1000 A

EP Type

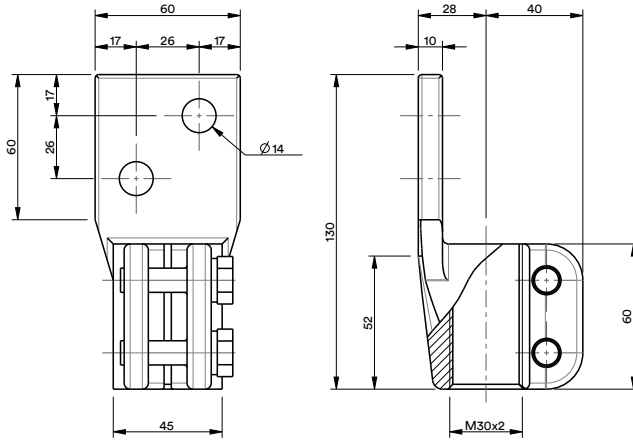

Item	Description	Q.ty
1	Flag EP	1
2	Washer DIN 125 A	2
3	Screw DIN 933	2

ER Type

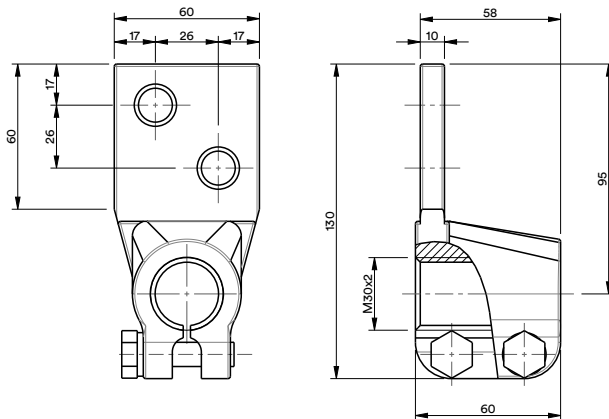

Item	Description	Q.ty
1	Flag ER	1
2	Washer DIN 125 A	2
3	Screw DIN 933	2

C – DIN 43675-75

2000 A - 3150 A

FP Type

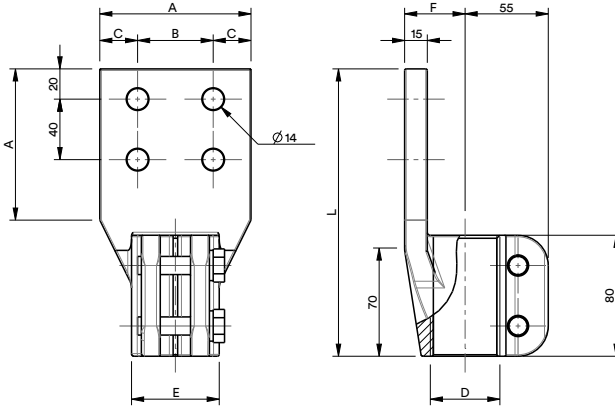

Item	Description	Q.ty
1	Flag FP	1
2	Washer DIN 125 A	2
3	Screw DIN 933	2

Current	D	A	B	C	E	F	L	Weight
2000 A	M42x3 42H9	100	50	25	58	40	190	3.5 kg
3150 A	M48x3 42H9	120	60	30	68	45	210	4.5 kg

FR Type

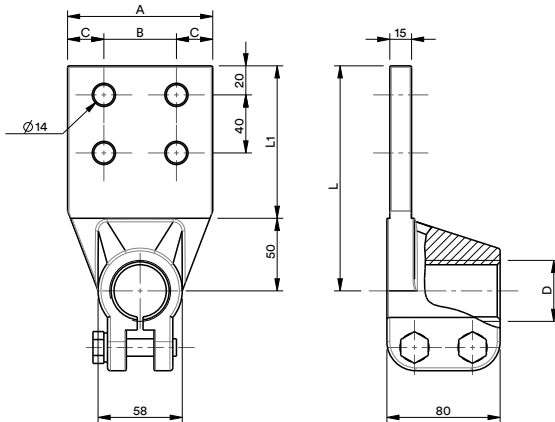

Item	Description	Q.ty
1	Flag FR	1
2	Washer DIN 125 A	2
3	Screw DIN 933	2

Current	D	A	B	C	E	L	L1	Weight
2000 A	M42x3 42H9	100	50	25	58	155	105	3.5 kg
3150 A	M48x3 42H9	120	60	30	68	175	125	4.5 kg

C – DIN 43675-75

5000 A

TP 78-120 Type

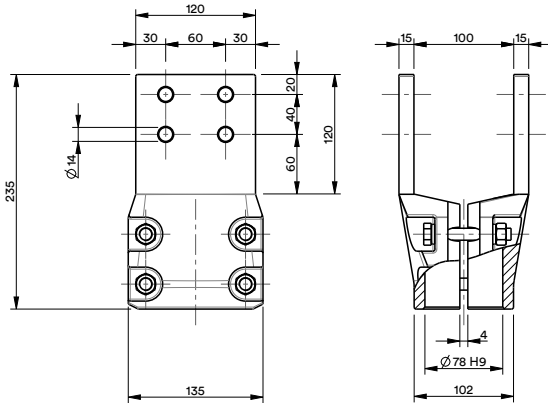

Item	Description	Q.ty
1	Semiflag	2
2	Washer DIN 125 A	4
3	Screw DIN 933	4
4	Full nut	4

8000 A

TP 78-180 Type

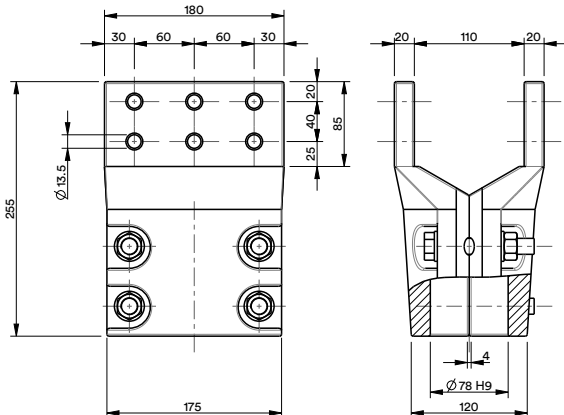

Item	Description	Q.ty
1	Semiflag	2
2	Washer DIN 125 A	4
3	Screw DIN 933	4
4	Full nut	4

C – UNEL 38137-67

630 A - 1000 A

6 Type - 10 Type

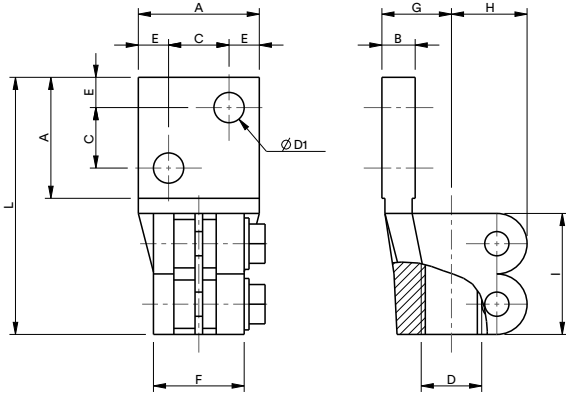

Item	Description	Q.ty
1	Flag	1
2	Washer DIN 125 A	2
3	Screw DIN 933	2

Type	Current	A	B	C	D	D1	E	F	G	H	I	L	Weight
6	630 A	40	11	20	M20	10	10	30	23	28	40	85	0.45 kg
10	1000 A	60	12	32	M30x2	14	14	45	30	40	60	130	1.2 kg

2000 A - 3150 A

20 Type - 31 Type

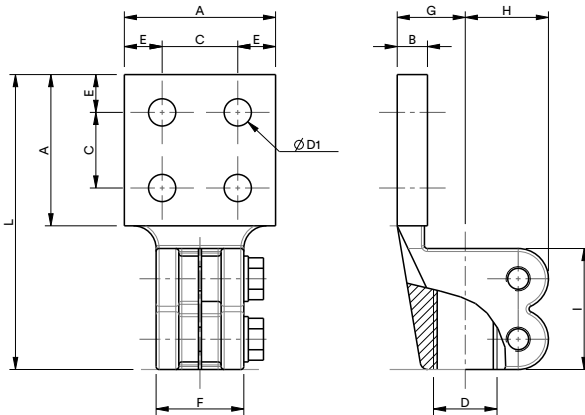

Item	Description	Q.ty
1	Flag	1
2	Washer DIN 125 A	2
3	Screw DIN 933	2

Type	Current	A	B	C	D	D1	E	F	G	H	I	L	Weight
20	2000 A	100	20	50	M42x3	18	25	58	45	55	80	195	4 kg
31	3150 A	120	20	60	M48x3	18	30	68	45	55	80	220	4.9 kg

C – UNE 20-176-89

1000 A

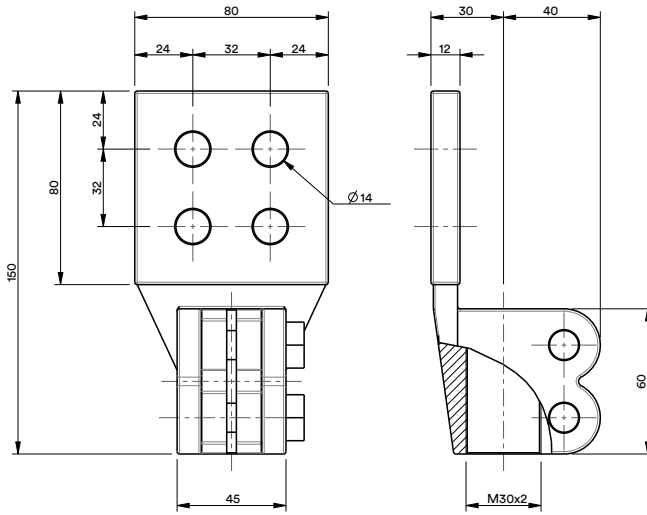

Item	Description	Q.ty
1	Flag	1
2	Washer DIN 125 A	2
3	Screw DIN 933	2

C – COMEM

250 A

2-009 Type

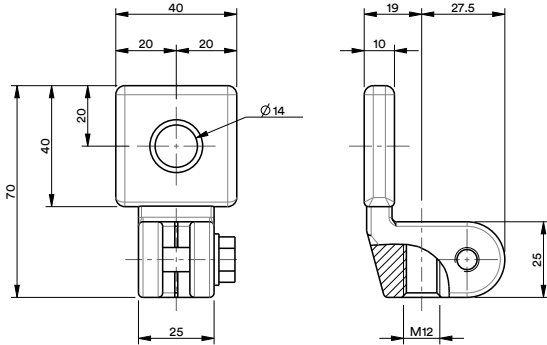

Item	Description	Q.ty
1	Flag	1
2	Washer DIN 125 A	1
3	Screw DIN 933	1

630 A

AF 06 Type

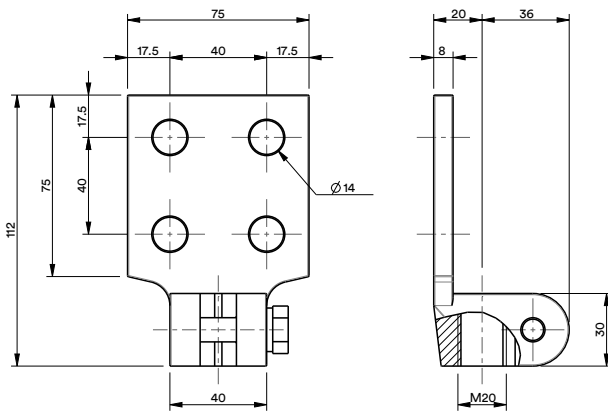

Item	Description	Q.ty
1	Flag	1
2	Washer DIN 125 A	1
3	Screw DIN 933	1

C – COMEM

1000 A

AF 1 Type

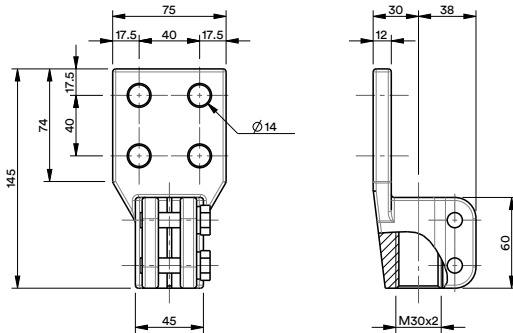

Item	Description	Q.ty
1	Flag	1
2	Washer DIN 125 A	2
3	Screw DIN 933	2

10-086 Type

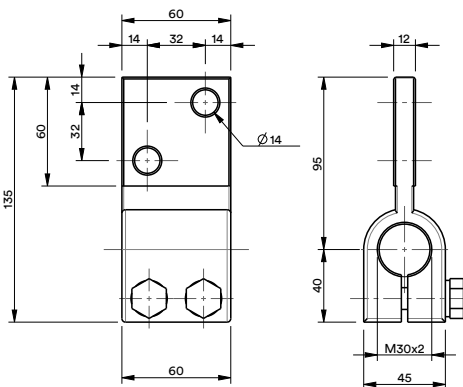

Item	Description	Q.ty
1	Flag	1
2	Washer DIN 125 A	2
3	Screw DIN 933	2

C – COMEM

2000 A

AF 2 Type

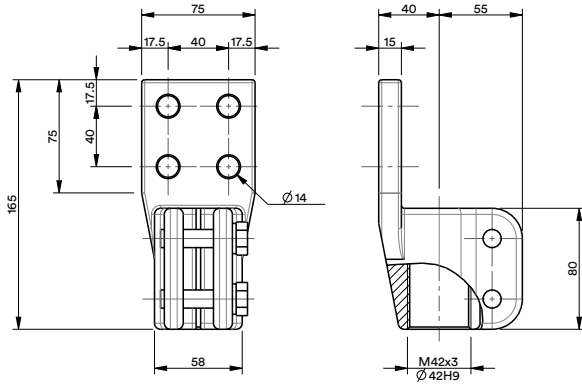

Item	Description	Q.ty
1	Flag	1
2	Washer DIN 125 A	2
3	Screw DIN 933	2

20-072 Type

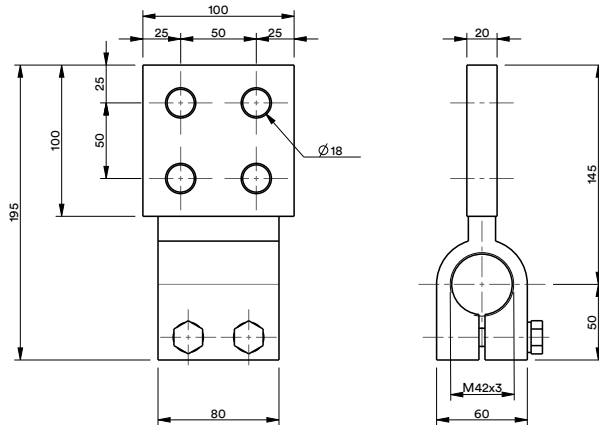

Item	Description	Q.ty
1	Flag	1
2	Washer DIN 125 A	2
3	Screw DIN 933	2

C – COMEM

3150 A

AF 3 Type

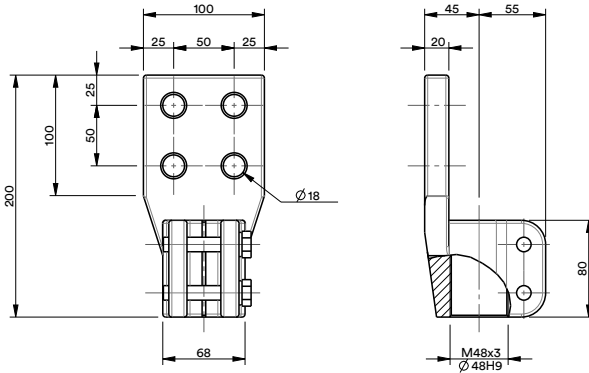

Item	Description	Q.ty
1	Flag	1
2	Washer DIN 125 A	2
3	Screw DIN 933	2

31-073 Type

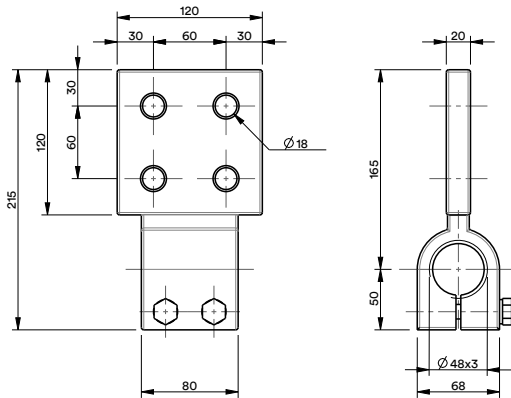

Item	Description	Q.ty
1	Flag	1
2	Washer DIN 125 A	2
3	Screw DIN 933	2

C – COMEM

4500 A

4500 A Type

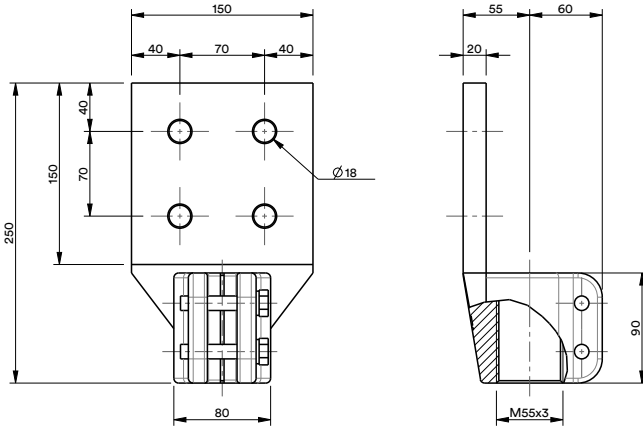

Item	Description	Q.ty
1	Flag	1
2	Washer DIN 125 A	2
3	Screw DIN 933	2

FR Type

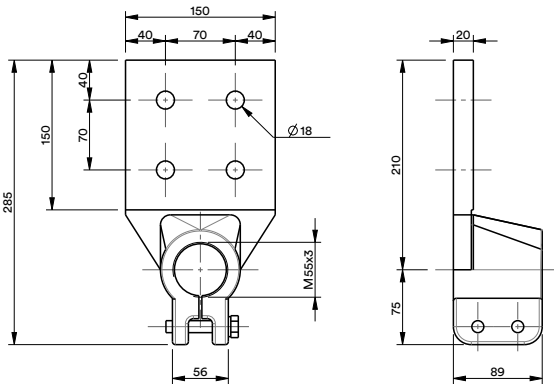

Item	Description	Q.ty
1	Flag	1
2	Washer DIN 125 A	2
3	Screw DIN 933	2

C – COMEM

U 6300 A Type

U 6300 A Type

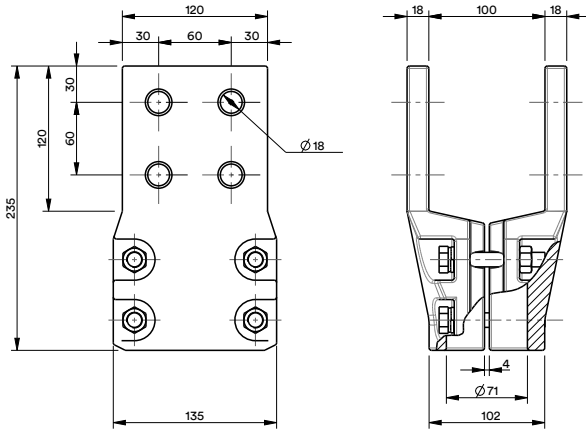

Item	Description	Q.ty
1	Half-flag	2
2	Washer DIN 125 A	4
3	Screw DIN 933	4
4	Full nut	4

Lower flag 6300 A

L 6300 A Type

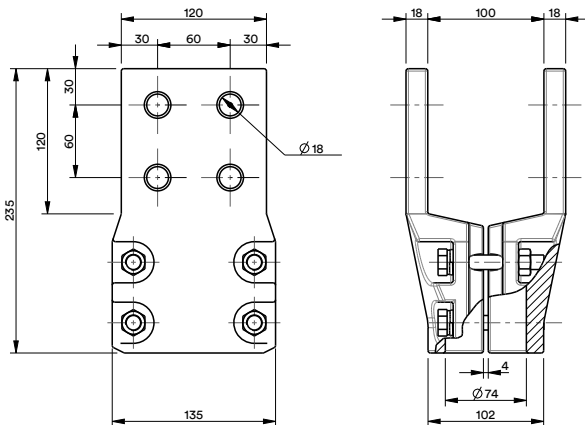

Item	Description	Q.ty
1	Half-flag	2
2	Washer DIN 125 A	4
3	Screw DIN 933	4
4	Full nut	4

C – COMEM

5000 A

TP 5000 A Type

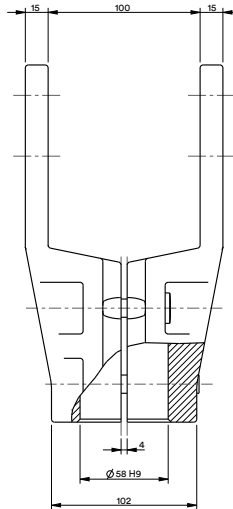
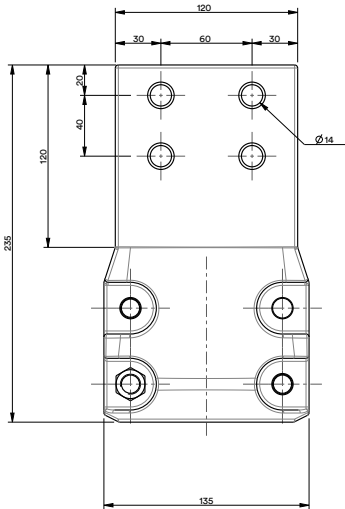

Item	Description	Q.ty
1	Half-flag	2
2	Washer DIN 125 A	4
3	Screw DIN 933	4
4	Full nut	4

**COMEM SpA**

Località Signolo 22, S.R.11
36054 Montebello Vicentino
Vicenza - Italy
Tel +39 0444 449 311

This installation manual contains essential information for the user required to install & operate the product.
In case you need any further information, contact us at customerservice@it.comem.com

www.comem.com

The data and illustrations are not binding. We reserve the right to modify the contents of this document without prior notice following the technical and product developments.

Copyright 2024 COMEM. All rights reserved

Manual-05-2024